

**KEF**

Your Haier Biomedical Partner



**Qingdao Haier Biomedical Co., Ltd.**

No.280 Feng Yuan Road, High-tech Zone,  
Qingdao, 266111, P.R. China  
E-mail: [inquiry@haierbiomedical.com](mailto:inquiry@haierbiomedical.com)  
Website: [www.haiermedical.com](http://www.haiermedical.com)



Haier Biomedical  
International



Haier Biomedical  
International



@haiermedicalint



Haier Biomedical  
International



Haier Biomedical  
International

Note: If a slight difference occurs between pictures and actual products, please refer to actual products. Our company reserves the right of final interpretation of this brochure, please contact us for any further information if required.

Mar.2025

# Pharmacy Refrigerator Solutions

# KEFÖ

Model	Tip uređaja	Šifra / Opis	Temperaturni opseg	Namena	Cena (kom)
HLR-118SF ATEX	Lab Refrigerator	BE0693EBA	3°C ~ 16°C	ATEX frižider za hemikalije	900.00 €
HLR-310SF ATEX	Lab Refrigerator	BE0FZ2EBA	3°C ~ 16°C	ATEX frižider za hemikalije	1,100.00 €
HYC-341GD (USB)	Pharmacy Refrigerator	(2~8C)	2°C ~ 8°C	Frižider za apoteke, čuvanje podloga	1,200.00 €
HYC-130FD (USB)	Pharmacy Refrigerator	(2~8C)	2°C ~ 8°C	Frižider za apoteke, čuvanje podloga	850.00 €

NA LAGERU KRAJEM MARTA 2026.

# CONTENTS

Chromatography Refrigerator .....	03
New Generation Pharmacy Refrigerator .....	05
RFID Refrigerator .....	21
Advanced Pharmacy Refrigerator with Touchscreen .....	25
Advanced Pharmacy Refrigerator with LED Display .....	26
Standard Pharmacy Refrigerator .....	29
Under-Counter Pharmacy Refrigerator .....	45
Combined Refrigerator and Freezer .....	49
Laboratory Refrigerator .....	53
Spark Free Refrigerator .....	55
Combined Refrigerator and Freezer with Spark-free Interior .....	59
Fluid Warming Cabinet .....	61

# Chromatography Refrigerator

03/04

Used for biochemical chromatographic analysis in laboratories, universities and other facilities.

## Product Advantages



### Professional Chromatography Refrigerator

- Large volume of 1100L
- Waterproof sockets provides power for mixers, shakers and other lab tools
- Robust frame and clamp securely hold experimental apparatus
- UV lamp ensures thorough sterilization within the chamber
- Corrosion-proof and easy-to-clean stainless steel interior



Top-mounted key lock for convenience



Adjustable perforated stainless steel shelves promote better circulation and flexible storage



Two access ports (one on each side wall)



4 swivel casters with 2 leveling feet for easy movement and positioning



Hydrocarbon refrigerant (R290) and CFC-free polyurethane insulation



USB, RS485 & printer for easy data export and external connection



Microprocessor controller, digital display with 0.1° C resolution; hermetically sealed compressor, forced-air circulation with auto defrost to ensure a cabinet temperature between 2-8°C



Double-layer tempered glass door with heater prevents condensation even at 32° C, 80% RH ambient, self-closing mechanism, magnetic door gasket for positive seal



Multiple alarm functions for safer monitoring, audible & visual alert with mute function, including standard remote alarm modules



Energy-efficient interior LED lighting provides bright, high color illumination at lower heat output









## Specifications

	Model	HYC-1100C	
Technical Data	Cabinet Type	Upright, Glass Door	
	Climate Class	N, 16-32°C	
	Cooling Type	Forced Air Cooling	
	Defrost Mode	Auto	
	Refrigerant	R290, 90g	
	GWP(global warming potential)	3	
	Sound Level (dB(A))	43	
Performance	Temperature Range (°C)	2-8	
Control	Controller	Microprocessor	
	Display	LED	
Electrical Data	Power Supply (V/Hz)	220-240/50/60	
	Power (W)	600	
	Electrical Current (A)	2.7	
Dimensions	Capacity (L/Cu.Ft)	1100/38.8	
	Net/Gross Weight (approx)	(kg)	340/380
		(lbs)	750/838
	Interior Dimension (W*D*H)	(mm)	1315*570*1525
		(in)	51.8*22.4*60.0
	Exterior Dimension (W*D*H)	(mm)	1420*630*1980
		(in)	55.9*24.8*78.0
	Packing Dimension (W*D*H)	(mm)	1550*875*2100
(in)		61.0*34.5*82.7	
Container Load (20'/40'/40'H)	7/15/15		
Alarms	High/Low Temperature	Y	
	High Ambient Temperature	Y	
	Door Ajar	Y	
	Power Failure	Y	
	Low Battery	Y	
	Sensor Error	Y	
	Communication Failure	Y	
	Remote Alarm	Y	
Accessories	Caster	4	
	Foot	2	
	Porthole	2 L&R on each side	
	Clamp Fit	2 Sets	
	Shelves/Drawers	1 Supporting Frame + 2 Adjustable Shelves	
	Printer	Optional	
	Chart Recorder	Optional	
	USB Interface	Yes	
	RS485	Optional	
	Others	Certification	CE



# New Generation Pharmacy Refrigerator

Used for storage of medicines, vaccines, reagents, biological products and other items that require a temperature between 2-8°C in hospitals, pharmacies, pharmaceutical factories, clinics and laboratories as key examples.

## Product Advantages

-  High performance with low noise level: 37dB(A)
-  Low energy consumption 2.2kWh /day
-  Ergonomic & innovative design, 7" touch screen, easy to check the cabinet emperature, alarm & event records; authority management is standard to avoid unauthorized access or change in settings
-  Triple-paned tempered glass door with frame heater to reduce condensation even at 32° C, 80% RH ambient; self-closing door with 90° stop; magnetic gaskets to ensure a positive seal
-  Multiple alarm functions for safer monitoring, audible/visual alert with mute function; remote alarm contact is equipped as standard
-  Anti-freezing thermostat is available to protect store items from freezing, which is DIN13277 compliance
-  Energy efficient interior LED lighting, side-mounted for complete clear visibility of the internal area
-  Standard USB module to easily record and export cabinet temperature and alarm data; Standard RS485 port and remote alarm contact for ease of external connection; optional printer to efficiently export cabinet temp data
-  Microprocessor controller, smart inverter compressor, optimized air-cooling technology with auto defrost to ensure excellent cooling performance, defrost water to evaporate automatically



-  Two 25mm probe access ports on each side wall to accept user-provided monitoring equipment
-  Adjustable plastic-coated wire shelves for improved circulation and flexible storage, 4 swivel casters with 2 leveling feet for easy movement and fixing
-  Electromagnetic lock is standard to avoid unauthorized access



**HYC-1030GT**



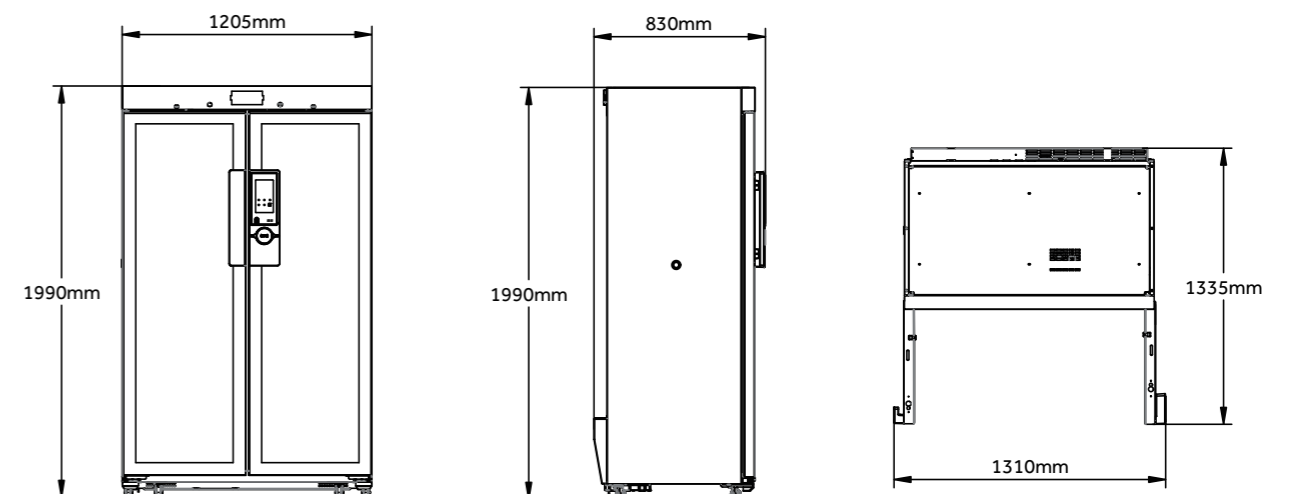







## Cabinet Temperature



# New Generation Pharmacy Refrigerator

Used for storage of medicines, vaccines, reagents, biological products and other items that require a temperature between 2-8°C in hospitals, pharmacies, pharmaceutical factories, clinics and laboratories etc.

## Product Advantages

-  Low energy consumption: 2.5 kWh/day<sup>①</sup>
-  Excellent performance: temperature uniformity  $\leq \pm 1^\circ\text{C}$ <sup>②</sup>
-  Quiet operation: 39dB (A)
-  Intelligent anti-condensation: triple-paned tempered glass door with door frame heater, effectively reduces condensation even at 32°C, 80% RH ambient temperature
-  Optional USB, RS485 and printer, easy to export temperature data; all events and alarms will be recorded by the USB module
-  Eco-friendly hydrocarbon refrigerant (R290) and CFC-free polyurethane insulation for reduced global warming
-  Hermetically sealed compressor, forced-air circulation and automatic defrost to ensure high cooling performance
-  Self-closing door with magnetic gasket for positive seal
-  Microprocessor controller, display with resolution of 0.1°C
-  Multiple alarm functions for safer monitoring



**HYC-1031GD**

## Cabinet Temperature

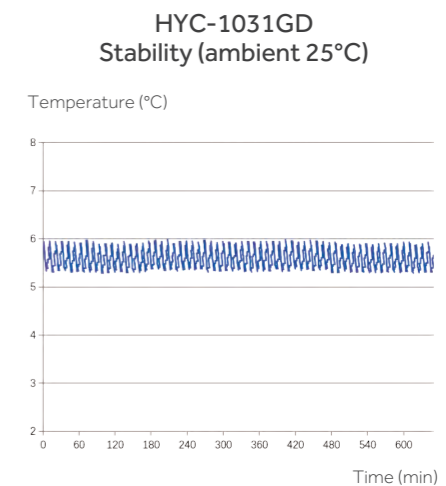
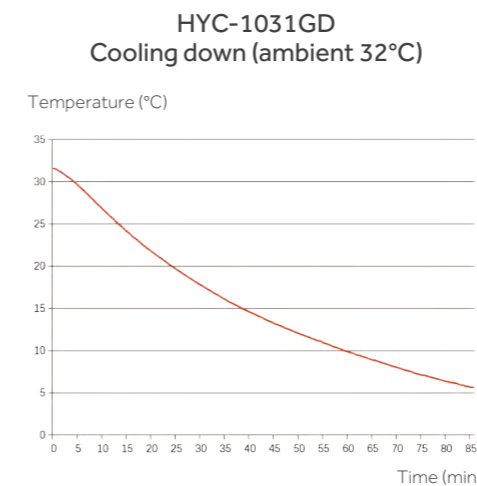

\* ①&②: Tested by TUV according to DIN13277

## New Generation Pharmacy Refrigerator

Used for storage of medicines, vaccines, reagents, biological products and other items that require a temperature between 2-8° C in hospitals, pharmacies, pharmaceutical factories, clinics and laboratories etc.

### Product Advantages



Eco-friendly hydrocarbon refrigerant (R290) and CFC- free polyurethane insulation for reduced global warming potential.



Hermetically sealed compressor, forced-air circulation with auto defrost to ensure high cooling performance, temperature uniformity  $\leq \pm 1.5^{\circ}\text{C}$ ; anti-freezing thermostat is available to protect store items from freezing.



Self-closing door hinge with 90° stop; Magnetic gaskets to ensure a positive seal.



Energy efficient interior LED lighting, side-mounted to enlighten full space.



Optional USB module to easily record and export cabinet temperature and alarm data; optional RS485 port for easily external connection; optional printer to easily export cabinet temp data .



Two 25mm probe access port on each side wall to accept user-provided monitoring equipment.



Multiple alarm functions for safer monitoring, audible/visual alert with mute function; remote alarm contact is equipped as standard.



Convenient security with a top-mounted unique-key lock.



4 swivel casters with 2 leveling feet for easily movement and fixing.



Microprocessor controller, digital display with 0.1° C resolution; easy to check the min/max temperature in the past 24 hours.



Adjustable plastic-coated wire shelves for improved circulation and flexible storage.



**HYC-1031FD**

### Product Dimension

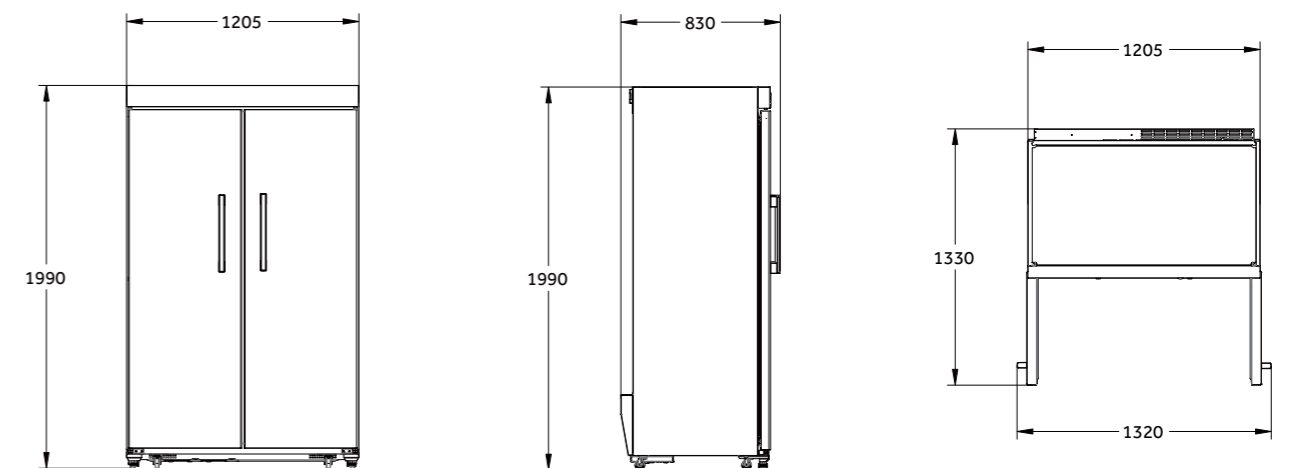

Front view

Side view

Top view

# New Generation Pharmacy Refrigerator

## Specifications

Model	HYC-1030GT		HYC-1031GD		HYC-1031FD	
<b>Technical Data</b>	Cabinet Type	Upright, Glass Door		Upright, Glass Door	Upright, Solid Door	
	Climate Class	N, 16-32°C		N, 16-32°C	N, 16-32°C	
	Cooling Type	Forced Air Cooling		Forced Air Cooling	Forced Air Cooling	
	Defrost Mode	Auto		Auto	Auto	
	Refrigerant	R600a		R290	R290	
	GWP (global warming potential)	20		3	3	
	Sound Level (dB(A))	37		39	39	
<b>Performance</b>	Temperature Range (°C)	2-8		2-8	2-8	
<b>Control</b>	Controller	Microprocessor		Microprocessor	Microprocessor	
	Display	LED		LED	LED	
<b>Electrical Data</b>	Power Supply (V/Hz)	220-240/50/60		220-240/50/60	220-240/50/60	
	Electrical Current (A)	2.2		2.2	3.6	
<b>Performance Characteristics</b>	Temperature Sensor	NTC		NTC	NTC	
	Power Consumption (kWh/24h)	2.2		2.48	2.04	
<b>Dimensions</b>	Capacity (L/Cu.Ft)	1030 / 36.4		1031/36.4	1031 / 36.4	
	Net/Gross Weight (approx)	(kg)	265/275		255/265	255/265
		(lbs)	584/606		562/584	562/584
	Interior Dimensions (W*D*H)	(mm)	1115*590*1670		1115*590*1670	1115*590*1670
		(in)	43.9*23.2*65.7		43.9*23.2*65.7	43.9*23.2*65.7
	Exterior Dimensions (W*D*H)	(mm)	1205*830*1990		1205*800*1990	1205*830*1990
		(in)	47.4*32.7*78.3		47.4*31.5*78.3	47.4*32.7*78.3
	Packing Dimensions (W*D*H)	(mm)	1310*925*2150		1310*925*2150	1310*925*2150
(in)		51.6*36.4*84.6		51.6*36.4*84.6	51.6*36.4*84.6	
<b>Alarms</b>	Container Load (20'/40'/40'H)	10/21/21		10/21/21	10/21/21	
	High/Low Temperature	Y		Y	Y	
	High Ambient Temperature	Y		Y	Y	
	Door Ajar	Y		Y	Y	
	Power Failure	Y		Y	Y	
	Low Battery	Y		Y	Y	
	Sensor Error	Y		Y	Y	
	Communication Failure	Y		Y	Y	
	Condenser Heat	Y		Y	Y	
	Remote Alarm	Y		Y	Y	
<b>Accessories</b>	Audible and Visual Alarm	Y		Y	Y	
	Caster	4		4	4	
	Foot	2		2	2	
	Porthole	2		2	2	
	Shelves/Drawers	14/-		14/-	14/-	
	Printer	Optional		Optional	Optional	
	Chart Recorder	N/A		N/A	N/A	
	USB Interface	Standard		Optional	Optional	
	RS485	Optional		Optional	Optional	
	Electromagnetic Lock	Standard		N/A	N/A	
	Plastic Basket	Optional		Optional	Optional	
	<b>Material</b>	Exterior Material	Painted Steel		Painted Steel	Painted Steel
Interior Material		Painted Steel		Painted Steel	Painted Steel	
Door Thickness (mm)		50		50	50	
Cabinet Thickness (mm)		45		45	45	
Shelves Material		Steel Wire, Coated with Plastic		Steel Wire, Coated with Plastic	Steel Wire, Coated with Plastic	
No. of Shelves		12+2		12+2	12+2	
<b>Others</b>	Certification	CE, DIN13277 (Optional)	CE, DIN13277 (Optional)	UL, Energy Star	CE, DIN13277 (Optional)	

Used for storage of medicines, vaccines, reagents, biological products and other items that require a temperature between 2-8° C in hospitals, pharmacies, pharmaceutical factories, clinics and laboratories etc.



## Product Advantages



Eco-friendly hydrocarbon refrigerant (R600a) and CFC- free polyurethane insulation for reduced global warming potential



Hermetically sealed compressor, forced-air circulation with auto defrost to ensure superior cooling performance, temperature uniformity  $\leq \pm 1.5^\circ\text{C}$ ; and a anti-freezing thermostat is available to protect store items from freezing



Optional USB module to easily record and export cabinet temperature and alarm data; optional RS485 port for effortless external connection; and optional printer to export cabinet temperature data



Multiple alarm functions for safer monitoring, audible/visual alert with mute function; remote alarm contact is equipped as standard



Convenient security with a top-mounted unique-key lock



Adjustable plastic-coated wire shelves for improved circulation and flexible storage



**HYC-461GD:**  
Triple-paned tempered glass door with frame heater to reduce condensation even at 32° C, 80% RH ambient; self- closing door hinge; magnetic gaskets to ensure a positive seal  
**HYC-461FD:**  
Self-closing door hinge; Magnectic gaskets to ensure a positive seal



Energy efficient interior LED lighting, side-mounted to enlighten full space



A  $\phi$  25mm probe access port is standard on side wall to accept user-provided monitoring equipment



4 swivel casters with 2 leveling feet for easy movement and fixing



Microprocessor controller, digital display with 0.1°C resolution; easy to check the min/max temperature in the past 24 hours; password protect function is available to avoid unauthorized setting.

# New Generation Pharmacy Refrigerator

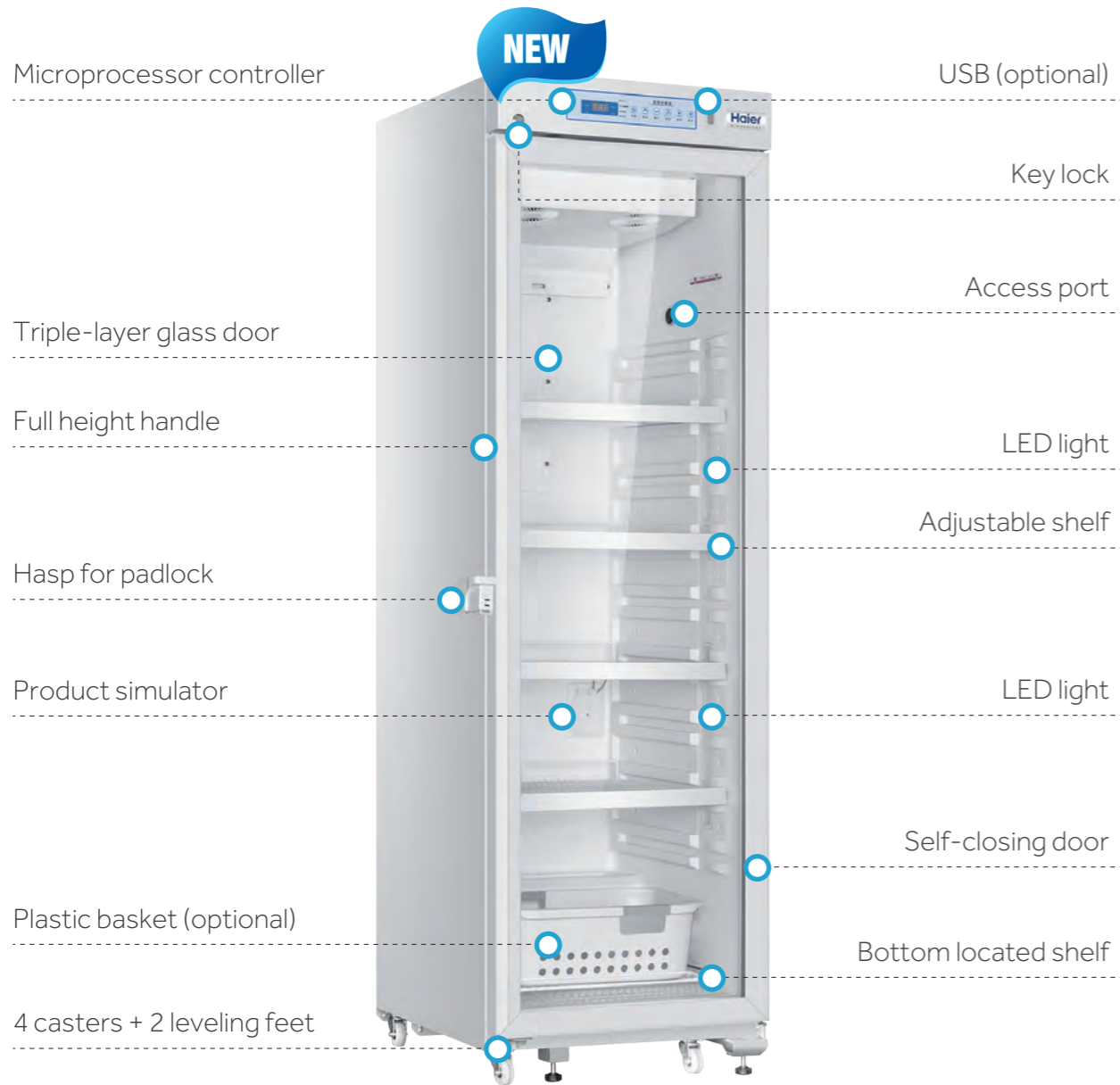

**HYC-461GD**

## Specifications

Model		HYC-461GD	HYC-461GD (115V)	HYC-461FD	HYC-461FD (115V)	
Technical Data	Cabinet Type	Upright, Glass Door		Upright, Solid Door		
	Climate Class	N, 16-32°C		N, 16-32°C		
	Cooling Type	Forced Air Cooling		Forced Air Cooling		
	Defrost Mode	Auto		Auto		
	Refrigerant	R600a		R600a		
	GWP (global warming potential)	20		20		
	Sound Level (dB(A))	37		37		
Performance	Temperature Range (°C)	2-8		2-8		
Control	Controller	Microprocessor		Microprocessor		
	Display	LED		LED		
Electrical Data	Power Supply (V/Hz)	220-240/50	115/60	220-240/50	115/60	
	Power(W)	310	230	310	230	
	Electrical Current (A)	1.7	3.1	1.7	3.1	
Performance Characteristics	Temperature Sensor	NTC		NTC		
	Power Consumption (kWh/24h)	1.85	1.33	1.85	1.33	
Dimensions	Capacity (L/Cu.Ft)	461/16.3		461 / 16.3		
	Net/Gross Weight (approx)	kg	115/125		115/125	
		lbs	254/276		254/276	
	Interior Dimensions (W*D*H)	mm	500*590*1670		500*590*1670	
		in	19.7*23.2*65.7		19.7*23.2*65.7	
	Exterior Dimensions (W*D*H)	mm	595*800*1990		595*800*1990	
		in	23.4*31.5*78.3		23.4*31.5*78.3	
	Packing Dimensions (W*D*H)	mm	720*930*2100		720*930*2100	
		in	28.3*36.6*82.7		28.3*36.6*82.7	
Container Load (20'/40'/40'H)	18/37/37		18/37/37			
Alarms	High/Low Temperature	Y		Y		
	High Ambient Temperature	Y		Y		
	Door Ajar	Y		Y		
	Power Failure	Y		Y		
	Low Battery	Y		Y		
	Sensor Error	Y		Y		
	Communication Failure	Y		Y		
	Condenser Heat	Y		Y		
	Remote Alarm	Y		Y		
Accessories	Caster	4		4		
	Foot	2		2		
	Porthole	2		2		
	Shelves/Drawers	6/-		6/-		
	Printer	Optional		Optional		
	Chart Recorder	N/A		N/A		
	USB Interface	Optional		Optional		
	RS485	Optional		Optional		
	Electromagnetic Lock	N/A		N/A		
	Plastic Basket	Optional		Optional		
Material	Exterior Material	Painted Steel		Painted Steel		
	Interior Material	Polystyrene		Polystyrene		
	Door Thickness (mm)	50		50		
	Cabinet Thickness (mm)	45		45		
Others	Certification	CE, DIN13277 (Optional)	UL, Energy Star	CE, DIN13277 (Optional)	UL, Energy Star	

# New Generation Pharmacy Refrigerator

Used for storage of medicines, vaccines, reagents, biological products and other items in hospitals, pharmacies, pharmaceutical factories, clinics and laboratories etc.



HYC-130GD/FD

- Purpose-built for medical and laboratory use
- High performance with low noise level
- Eco-friendly and energy saving
- Condensation free even at ambient 32°C & 80% RH
- Convenient monitoring and data acquisition

## Product Features

- Eco-friendly hydrocarbon refrigerant (R600a) and CFC-free polyurethane insulation for reduced global warming potential
- Hermetically sealed compressor, forced-air circulation with auto defrost to ensure high cooling performance
- Adjustable plastic-coated wire shelves for improved circulation and flexible storage
- 25mm probe access port to accept user- provided monitoring equipment
- Optional USB, optional RS485 for easy data acquisition
- Quiet operation with noise level of only 37dB(A)
- HYC-130GD:** Triple layer glass door with frame heater to achieve condensation free even at 32°C, 80% RH ambient; magnetic gaskets to ensure a positive seal
- HYC-130FD:** Self-closing door hinge with 10° stop; Magnetic gaskets to ensure a positive seal
- Multiple alarm functions for safer monitoring, audible/ visual alert with mute function; remote alarm contacts as standard in rear of the unit
- Easy to check the min/max temperature in the past 24 hours
- Microprocessor controller, wipe clean display with 0.1°C resolution for accurate control
- Energy efficient interior LED lighting

## Product Details

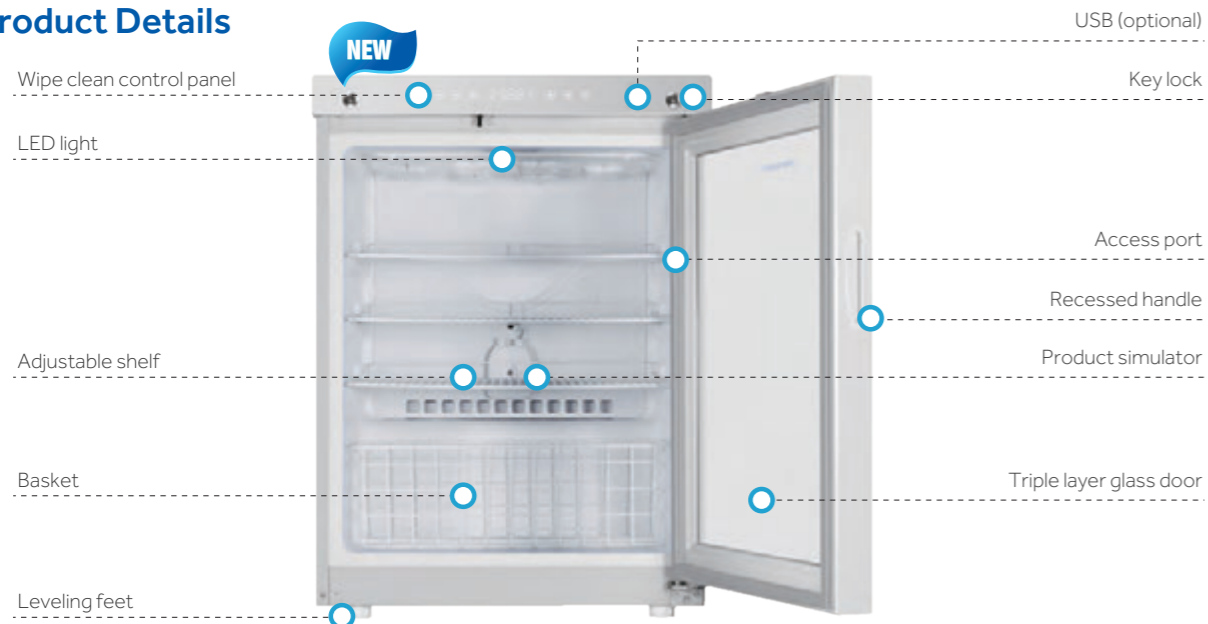

## Specifications

Model		HYC-130GD	HYC-130GD (115V)	
Technical Data	Cabinet Type	Under-Counter, Glass Door		
	Climate Class (°C)	N, 16-32		
	Cooling Type	Forced Air Cooling		
	Defrost Mode	Auto		
	Refrigerant	R600a, 30g		
	GWP (Global Warming Potential)	20		
Performance	Sound Level (dB(A))	37		
	Temperature Range (°C)	2-8		
Control	Will the fan stop automatically when opening the door	Y		
	Controller	Microprocessor		
	Display	LED		
Electrical Data	Power Supply (V/Hz)	220-240/50/60	115/60	
	Power (W)	180		
Performance Characteristics	Temperature Sensor	NTC		
	Power Consumption (kWh/24h)	1		
Dimensions	Capacity (L/Cu.Ft)	130 / 4.6		
	Net/Gross Weight (approx)	kg	48 / 52	
		lbs	105.8 / 114.6	
	Interior Dimensions (W*D*H)	mm	515*455*625	
		in	20.3*17.9*24.6	
	Exterior Dimensions (W*D*H)	mm	595*670*840	
		in	23.4*26.4*33.1	
	Packing Dimensions (W*D*H)	mm	670*730*890	
in		26.4*28.7*35.0		
Alarms	Container Load (20°/40°/40°H)	48/102/102		
	High/Low Temperature	Y		
	High Ambient Temperature	Y		
	Door Ajar	Y		
	Power Failure	Y		
	Low Battery	Y		
	Sensor Error	Y		
	Communication Failure	Y		
	Condenser Heat	N		
	Remote Alarm	Y		
	Audible and Visual Alarm	Y		
	Accessories	Caster	2	
Foot		2		
Porthole		1 Right Side Wall		
Shelves/Basket		3/1		
Printer		N/A		
Chart Recorder		N/A		
USB Interface		Optional		
RS485		Optional		
Material	Exterior Material (mm)	Painted Steel		
	Insulation Material (mm)	Polystyrene		
	Door Thickness	50		
	Cabinet Thickness	45		
	Shelves Material	Steel Wire, Coated with Plastic		
Others	Certification	CE, UKCA, DIN13277 (Optional)	UL, Energy Star (to be issued)	

## New Generation Pharmacy Refrigerator

Model		HYC-130FD	HYC-130FD(115V)	
Technical Data	Cabinet Type	Under-Counter, Solid Door		
	Climate Class (°C)	N, 16-32		
	Cooling Type	Forced Air Cooling		
	Defrost Mode	Auto		
	Refrigerant	R600a, 30g		
	GWP (Global Warming Potential)	20		
	Sound Level (dB(A))	37		
Performance	Temperature Range (°C)	2-8		
Control	Will the fan stop automatically when opening the door	Y		
	Controller	Microprocessor		
	Display	LED		
Electrical Data	Power Supply (V/Hz)	220-240/50/60	115/60	
	Power (W)	180		
Performance Characteristics	Temperature Sensor	NTC		
	Power Consumption (kWh/24h)	0.55		
Dimensions	Capacity (L/Cu.Ft)	130 / 4.6		
	Net/Gross Weight (approx)	kg	48 / 52	
		lbs	105.8 / 114.6	
	Interior Dimensions (W*D*H)	mm	515*455*625	
		in	20.3*17.9*24.6	
	Exterior Dimensions (W*D*H)	mm	595*670*840	
		in	23.4*26.4*33.1	
	Packing Dimensions (W*D*H)	mm	670*730*890	
		in	26.4*28.7*35.0	
	Container Load (20'/40'/40'H)	48/102/102		
Alarms	High/Low Temperature	Y		
	High Ambient Temperature	Y		
	Door Ajar	Y		
	Power Failure	Y		
	Low Battery	Y		
	Sensor Error	Y		
	Communication Failure	Y		
	Condenser Heat	N		
	Remote Alarm	Y		
	Audible and Visual Alarm	Y		
	Accessories	Caster	2	
Foot		2		
Porthole		1 Right Side Wall		
Shelves/Basket		3/1		
Printer		N/A		
Chart Recorder		N/A		
USB Interface		Optional		
RS485		Optional		
Material		Exterior Material (mm)	Painted Steel	
	Insulation Material (mm)	Polystyrene		
	Door Thickness	50		
	Cabinet Thickness	45		
	Shelves Material	Steel Wire, Coated with Plastic		
Others	Certification	CE, UKCA, DIN13277 (Optional)	UL, Energy Star(to be issued)	

Used for storage of medicines, vaccines, reagents, biological products and other items that require a temperature between 2-8°C in hospitals, pharmacies, pharmaceutical factories, clinics and laboratories etc.



## Product Advantages



User reversible door hinge



**HYC-85GD:**

Intelligent anti-condensation: triple-paneled tempered glass door with door frame heater, effectively reduces condensation even at 32°C, 80% RH ambient temperature

**HYC-85FD:**

CFC-free solid door, highly effective insulation



Excellent performance: temperature uniformity  $\leq \pm 1^\circ\text{C}$  ①



Optional USB and RS485, easy to export temperature data



Quiet operation: 35dB (A)



Eco-friendly hydrocarbon refrigerant (R600a) and CFC-free polyurethane insulation for reduced global warming



Magnetic gasket for positive seal



Hermetically sealed compressor, forced-air circulation and automatic defrost to ensure high cooling performance



Multiple alarms for safer monitoring



Microprocessor controller, display with resolution of 0.1°C

\* ① Tested by TUV according to DIN13277

# New Generation Pharmacy Refrigerator



## Cabinet Temperature

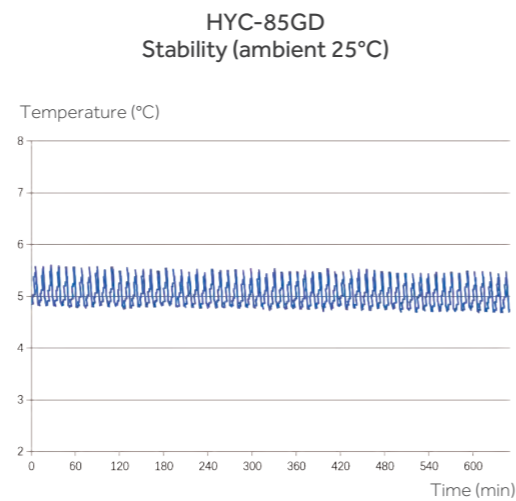
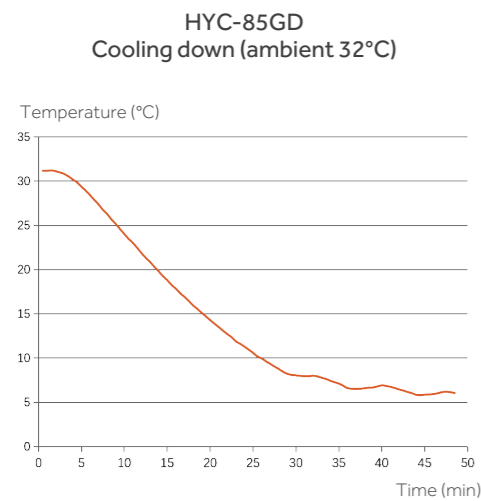

## Specifications

Model	HYC-85GD		HYC-85FD	
Technical Data	Cabinet Type	Counter-Top / Under-Counter, Glass Door		
	Climate Class (°C)	N, 16-32		
	Cooling Type	Forced Air Cooling		
	Defrost Mode	Auto		
	Refrigerant	R600a, 45g		
	GWP(global warming potential)	20		
	Sound Level (dB(A))	35		
Performance	Temperature Range (°C)	2-8		
	Will the fan stop automatically when opening the door	Y		
Control	Controller	Microprocessor		
	Display	LED		
Electrical Data	Power Supply (V/Hz)	220-240/50	115V/60	
	Electrical Current (A)	0.98	1.2	
Performance Characteristics	Temperature Sensor	NTC		
	Power Consumption (kWh/24h)	0.99	0.72	
Dimensions	Capacity (L/Cu.Ft)	85/3.0		
	Net/Gross Weight(approx)	kg	36 / 41	
		lbs	79.4 / 90.4	
	Interior Dimensions (W*D*H)	mm	405*405*555	
		in	15.9*15.9*21.9	
	Exterior Dimensions (W*D*H)	mm	495*550*740	
		in	19.5*21.7*29.1	
	Packing Dimensions (W*D*H)	mm	590*650*830	
		in	23.2*25.6*32.7	
	Container Load (20'/40'/40'H)	54/120/180		
Alarms	High/Low Temperature	Y		
	High Ambient Temperature	Y		
	Door Ajar	Y		
	Power Failure	Y		
	Low Battery	Y		
	Sensor Error	Y		
	Communication Failure	Y		
	Condenser Heat	N		
	Remote Alarm	Y		
	Audible and Visual Alarm	Y		
	Accessories	Caster	2	
		Foot	2	
Porthole		1		
Shelves/Basket		2/1		
Printer		N/A		
Chart Recorder		N/A		
USB Interface		Optional		
Material	RS485	Optional		
	Exterior Material	Painted Steel		
	Interior Material	Polystyrene		
	Door Thickness (mm)	50		
	Cabinet Thickness (mm)	45		
Other	Shelves Material	Steel Wire, Coated with Plastic		
	Certification	CE, UKCA, DIN13277 (Optional)	UL, Energy Star	

# RFID Refrigerator

## Smart Management of Medicine and Reagents Starts with IoT Technology

Perform statistical analysis of market data and medicine or reagents usage to report on market trends providing highly useful feedback to production and sales.



**HYC-509R**



### Smart IoT System Makes Storage Management Simple, Precise and Effective

RFID based smart IoT management system permits automatic management of stored products are automatically



Smart RFID label



Smart RFID shelf



Industrial-grade IoT Network Module Group



### Authorized Management for Material Flow at Controllable Risk

NFC authorized management system is traceable.



### Statistical Analysis of Test Data, Precise Verification and Scientific Instruction

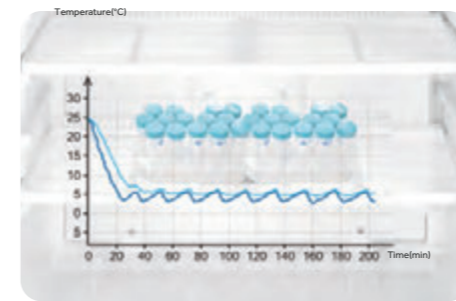

### Precise Temperature Control Ultimate Safety of Test Reagents

2°C - 8°C storage temperature, real-time monitoring of cabinet temperature



### Intelligent Accurate Recording

Intelligent touch screen for quick check of warehouse in-and-out records



### Manage Market Data to Support Scientific Production Scheduling

Perform statistical analysis of market data and medicine or reagents usage to report on market trends providing highly useful feedback to production and sales.



### Effective Management of Sales Channels

Sales channels can provide timely feedback information to improve shipping, refilling, dispatching and inventory control, to provide continuity on supply and to optimize inventory level.



### Reagent Handling Process is Traceable and Controllable

Shipping and receiving processes of reagents are automatically monitored and controlled for authorized users. Every box of reagents is traceable.

# RFID Refrigerator

## Smart Management of Products

(It is suitable for manufacturing industry)

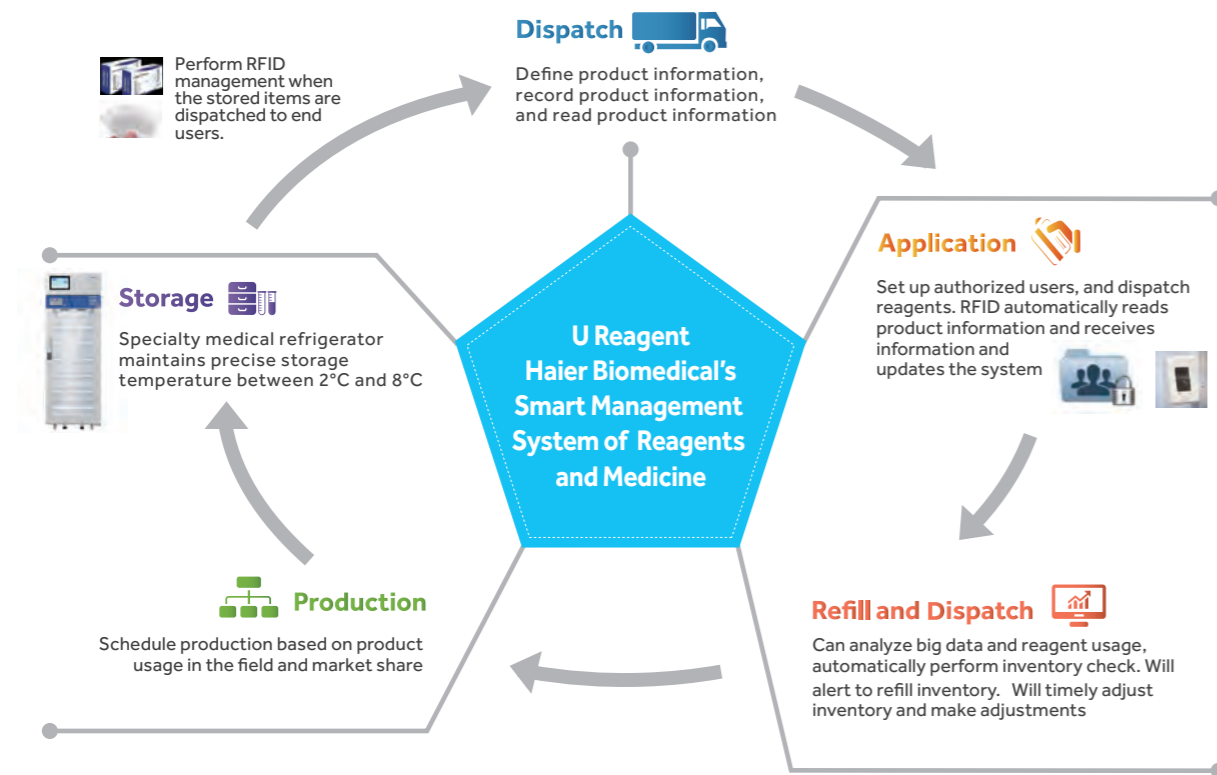

## From storage to use, the entire process is automatically and smartly controlled

(It is suitable for pharmaceutical factories, laboratories and hospitals)

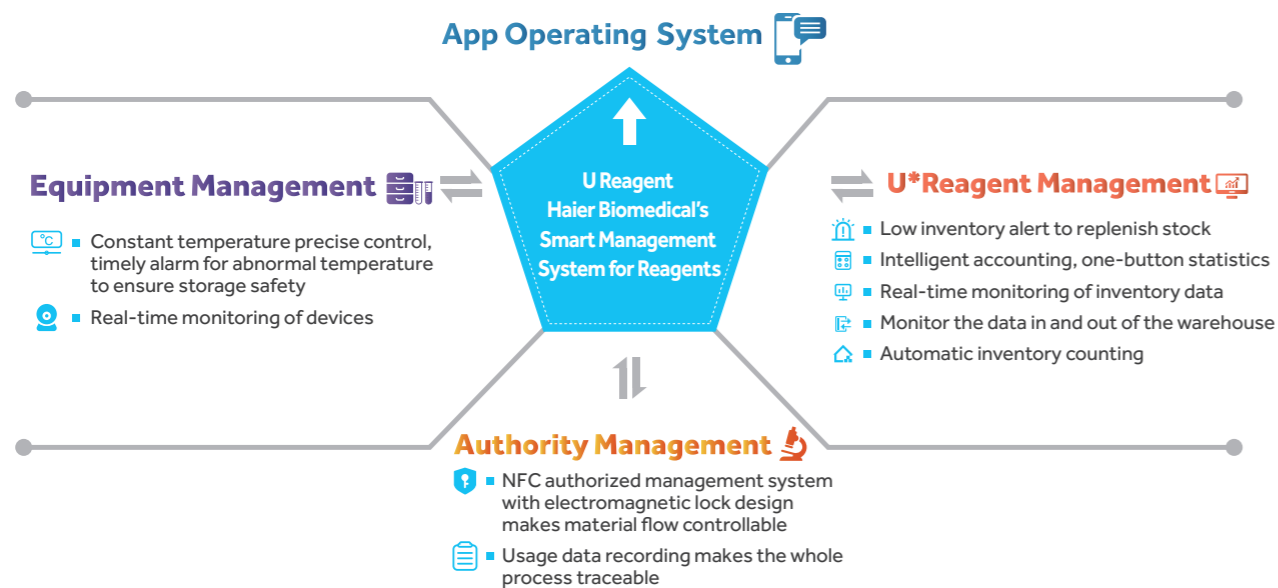

## Specifications

	Model	HYC-509R	
Technical Data	Cabinet Type	Upright, Single Glass Door	
	Climate Class	N	
	Cooling Type	Forced Air Cooling	
	Defrost Mode	Auto	
	Refrigerant	R600a	
	GWP (global warming potential)	20	
Performance	Temperature Range (°C)	2-8	
	Sound Level (dB(A))	40	
Control	Controller	Microprocessor	
	Display	Touchscreen + LED	
Electrical Data	Power Supply (V/Hz)	220-240/50/60	
	Electrical Current (A)	2	
	Power Consumption (kWh/day)	6	
Dimensions	Capacity (L/Cu.Ft)	509/17.97	
	Net/Gross Weight (approx)	(kg)	180/215
		(lbs)	396/473
	Interior Dimensions (W*D*H)	(mm)	593*585*1500
		(in)	23.21*22.9*58.8
	Exterior Dimensions (W*D*H)	(mm)	693*813*1981
		(in)	27.1*31.9*77.7
	Packing Dimensions (W*D*H)	(mm)	835*915*2170
(in)		32.9*36.0*85.4	
Container Load (20'/40'/40'H)		14/28/28	
Alarms	High/Low Temperature	Y	
	High Ambient Temperature	Y	
	Remote Alarm	Y	
	Power Failure	Y	
	Low Battery	Y	
	Door Ajar	Y	
Accessories	Caster	Y	
	Foot	Y	
	Porthole	Y	
	Shelves/Drawers	6	
Others	USB Interface	Y	
	Certification	CE	

## Advanced Pharmacy Refrigerator with Touchscreen

## Advanced Pharmacy Refrigerator with LED Display



HYC-1099TF

HYC-509T

HYC-1099T

HYC-509TF



HYC-1099F

HYC-509

HYC-1099

HYC-509F

### Product Advantages

- Microprocessor controller, 7-inch touch screen, easy to check the cabinet temperature graph, alarm & event records and other information; authority management is standard to avoid unauthorized access or incorrect settings
- Excellent cooling performance, temperature uniformity  $\pm 2^{\circ}\text{C}$ ; anti-freezing thermostat is equipped as standard, DIN13277 compliance
- Double-paned tempered glass door with electronic heater to reduce condensation even at  $32^{\circ}\text{C}$ , 80% RH ambient; self-closing door hinge with  $90^{\circ}$  stop; magnetic gaskets to ensure a positive seal (Solid door type is also available upon request)
- Electromagnetic lock is standard to avoid unauthorized access
- Energy efficient interior LED lighting

- Eco-friendly hydrocarbon refrigerant (R600a) and CFC-free polyurethane insulation for reduced global warming
- Hermetically sealed compressor, forced-air circulation with auto defrost to ensure high cooling performance
- Multiple alarm functions for safer monitoring, audible/visual alert with mute function; remote alarm contact is equipped as standard
- Adjustable plastic-coated wire shelves for improved circulation and flexible storage; fully extendable ABS drawer with divider is optional
- 25mm probe access port on side wall to accept user- provided monitoring equipment
- 4 universal casters with 2 leveling feet
- Standard USB module to conveniently record and export cabinet temperature and alarm data; standard RS485 port and remote alarm contact for efficient external connection; optional printer to export cabinet temperature data

### Product Advantages

- Double-paned tempered glass door with electronic heater to reduce condensation even at  $32^{\circ}\text{C}$ , 80% RH ambient; self-closing door hinge with  $90^{\circ}$  stop; magnetic gaskets to ensure a positive seal
- Microprocessor controller, digital display with  $0.1^{\circ}\text{C}$  resolution; easy to check the min/max temperature in the past 24 hours
- Adjustable plastic-coated wire shelves for improved circulation and flexible storage; fully extendable ABS drawer with divider is optional
- Convenient security with a top-mounted unique-key lock; electromagnetic lock is optional to avoid unauthorized access
- Eco-friendly hydrocarbon refrigerant (R600a) and CFC-free polyurethane insulation for reduced global warming
- Energy efficient interior LED lighting
- Standard USB module to conveniently record and export cabinet temperature and alarm data; Standard RS485 port and remote alarm contact for efficient external connection; optional printer to export cabinet temperature data
- Multiple alarm functions for safer monitoring, audible/visual alert with mute function; remote alarm contact is equipped as standard
- Excellent cooling performance, temperature uniformity  $\leq \pm 2^{\circ}\text{C}$ ; anti-freezing thermostat is equipped as standard, DIN13277 compliance
- Hermetically sealed compressor, forced-air circulation with auto defrost to ensure high cooling performance
- 25mm probe access port on side wall to accept user-provided monitoring equipment
- 4 universal casters with 2 leveling feet

# Advanced Pharmacy Refrigerator with Touchscreen

# Advanced Pharmacy Refrigerator with LED Display



## Specifications

Model		HYC-509T	HYC-509TF	HYC-1099T	HYC-1099TF	HYC-509	HYC-509F	HYC-1099	HYC-1099F	
Technical Data	Cabinet Type	Upright, Single Glass Door	Upright, Single Solid Door	Upright, Double Glass Door	Upright, Double Solid Door	Upright, Single Glass Door	Upright, Single Solid Door	Upright, Double Glass Door	Upright, Double Solid Door	
	Climate Class	N	N	N	N	N	N	N	N	
	Cooling Type	Forced Air Cooling	Forced Air Cooling	Forced Air Cooling	Forced Air Cooling	Forced Air Cooling	Forced Air Cooling	Forced Air Cooling	Forced Air Cooling	
	Defrost Mode	Auto	Auto	Auto	Auto	Auto	Auto	Auto	Auto	
	Refrigerant	R600a	R600a	R600a	R600a	R600a	R600a	R600a	R600a	
	GWP (global warming potential)	20	20	20	20	20	20	20	20	
	Sound Level (dB(A))	40	40	43	43	40	40	43	43	
Performance	Temperature Range (°C)	2-8	2-8	2-8	2-8	2-8	2-8	2-8	2-8	
Control	Will the fan stop automatically when opening the door	Y	Y	Y	Y	Y	Y	Y	Y	
	Controller	Microprocessor	Microprocessor	Microprocessor	Microprocessor	Microprocessor	Microprocessor	Microprocessor	Microprocessor	
	Display	Touchscreen	Touchscreen	Touchscreen	Touchscreen	LED	LED	LED	LED	
Electrical Data	Power Supply (V/Hz)	220-240/50/60	220-240/50/60	220-240/50/60	220-240/50/60	220-240/50/60	220-240/50/60	220-240/50/60	220-240/50/60	
	Electrical Current (A)	1.85	1.75	2.5	2.25	1.85	1.75	2.5	2.25	
Performance Characteristics	Temperature Sensor	PT100 + NTC	PT100 + NTC	PT100 + NTC	PT100 + NTC	PT100 + NTC	PT100 + NTC	PT100 + NTC	PT100 + NTC	
	Power Consumption (kWh/24h)	5.9	5.3	6.8	6	5.9	5.3	6.8	6	
Dimensions	Capacity (L/Cu.Ft)	509/17.97	509/17.97	1099/38.5	1099/38.5	509/17.97	509/17.97	1099/38.5	1099/38.5	
	Net/Gross Weight (approx)	kg	180/215	175/210	340/400	330/390	180/215	175/210	340/400	330/390
		lbs	396/473	385/462	748/1000	726/858	396/473	385/462	748/1000	726/858
	Interior Dimensions (W*D*H)	mm	593*585*1500	593*585*1500	1295*585*1500	1295*585*1500	593*585*1500	593*585*1500	1295*585*1500	1295*585*1500
		in	23.21*22.9*58.8	23.21*22.9*58.8	50.7*22.9*58.8	50.7*22.9*58.8	23.21*22.9*58.8	23.21*22.9*58.8	50.7*22.9*58.8	50.7*22.9*58.8
	Exterior Dimensions (W*D*H)	mm	693*813*1981	693*813*1981	1395*813*1981	1395*813*1981	693*813*1981	693*813*1981	1395*813*1981	1395*813*1981
		in	27.1*31.9*77.7	27.1*31.9*77.7	54.7*31.9*77.7	54.7*31.9*77.7	27.1*31.9*77.7	27.1*31.9*77.7	54.7*31.9*77.7	54.7*31.9*77.7
	Packing Dimensions (W*D*H)	mm	835*915*2170	835*915*2170	1550*895*2100	1550*895*2100	835*915*2170	835*915*2170	1550*895*2100	1550*895*2100
in		32.9*36.0*85.4	32.9*36.0*85.4	61.0*35.3*82.7	61.0*35.3*82.7	32.9*36.0*85.4	32.9*36.0*85.4	61.0*35.3*82.7	61.0*35.3*82.7	
	Container Load (20'/40'/40'H)	14/28/28	14/28/28	7/15/15	7/15/15	14/28/28	14/28/28	7/15/15	7/15/15	
Alarms	High/Low Temperature	Y	Y	Y	Y	Y	Y	Y	Y	
	High Ambient Temperature	Y	Y	Y	Y	Y	Y	Y	Y	
	Door Ajar	Y	Y	Y	Y	Y	Y	Y	Y	
	Power Failure	Y	Y	Y	Y	Y	Y	Y	Y	
	Low Battery	Y	Y	Y	Y	Y	Y	Y	Y	
	Sensor Error	Y	Y	Y	Y	Y	Y	Y	Y	
	Communication Failure	Y	Y	Y	Y	Y	Y	Y	Y	
	Remote Alarm	Y	Y	Y	Y	Y	Y	Y	Y	
	Audible and Visual Alarm	Y	Y	Y	Y	Y	Y	Y	Y	
Accessories	Condenser Overheat	Y	Y	Y	Y	Y	Y	Y	Y	
	Caster	Y	Y	Y	Y	Y	Y	Y	Y	
	Foot	Y	Y	Y	Y	Y	Y	Y	Y	
	Porthole	Y	Y	Y	Y	Y	Y	Y	Y	
	Test Hole	Y	Y	Y	Y	Y	Y	Y	Y	
	Shelves/Drawers	6 on each side, clearance 19.5cm/Optional	6 on Each Side, Clearance 19.5cm/Optional	12/Optional	12/Optional	6 on Each Side, Clearance 19.5cm/Optional	6 on Each Side, Clearance 19.5cm/Optional	12/Optional	12/Optional	
	Drawer Material	Steel Wire Dipping Plastic	Steel Wire Dipping Plastic	Steel Wire, Coated with Plastic	Steel Wire, Coated with Plastic	Steel Wire Dipping Plastic	Steel Wire Dipping Plastic	Steel Wire, Coated with Plastic	Steel Wire, Coated with Plastic	
USB Interface	Y	Y	Y	Y	Y	Y	Y	Y		
Material	Exterior Material	Painted Steel	Painted Steel	Painted Steel	Painted Steel	Painted Steel	Painted Steel	Painted Steel	Painted Steel	
	Interior Material	Painted Steel; Optional Stainless Steel	Painted Steel; Optional Stainless Steel	Painted Steel; Optional Stainless Steel	Painted Steel; Optional Stainless Steel	Painted Steel; Optional Stainless Steel	Painted Steel; Optional Stainless Steel	Painted Steel; Optional Stainless Steel	Painted Steel; Optional Stainless Steel	
	Door Thickness (mm)	50	50	50	50	50	50	50	50	
	Cabinet Thickness (mm)	50	50	50	50	50	50	50	50	
	Shelves Material	Steel Wire, Coated with Plastic	Steel Wire, Coated with Plastic	Steel Wire, Coated with Plastic	Steel Wire, Coated with Plastic	Steel Wire, Coated with Plastic	Steel Wire, Coated with Plastic	Steel Wire, Coated with Plastic	Steel Wire, Coated with Plastic	
	No. of Shelves	6	6	12	12	6	6	12	12	
Others	Certification	CE, UKCA, DIN13277 (Optional)	CE, UKCA, DIN13277 (Optional)	CE, UKCA	CE, UKCA	CE, UKCA, DIN13277 (Optional)	CE, UKCA, DIN13277 (Optional)	CE, UKCA, DIN (optional)	CE, UKCA, DIN (optional)	

# Standard Pharmacy Refrigerator

The product is used to store biological drugs and items at a temperature of 2-8°C. Typically used within pharmacy, pharma production, public health, hospitals and other life science laboratories.



**HYC-309**



## Superior performance

- Microcomputer controller, display/control accuracy 0.1°C
- Temperature range 2-8°C, temperature uniformity  $\pm 2^\circ\text{C}$
- Energy-efficient conversion compressors and non-toxic, environmentally-friendly hydrocarbon refrigerant
- Self-closing door design
- Electrically heated glass door prevents condensation
- Multiple interface options - USB, RS485 and printer



## Safe and reliable

- Key lock and provision for padlock to ensure safe and secure product storage
- Multiple alarms: High/Low temperature alarm, high ambient temperature alarm, door ajar alarm, power failure, low battery, sensor error, comms error and remote alarm contacts
- Alarm mode: Audible/visual and remote alarm with battery back-up which continuously alarms for up to 48 hours in the event of a power failure

## Temperature Curve

**HYC-309**  
Cooling down (ambient 32°C)

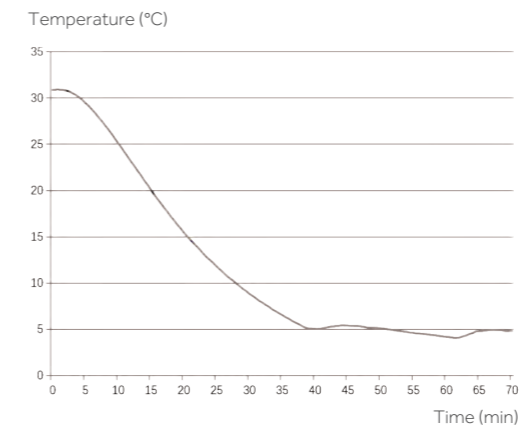

**HYC-309**  
Stability (ambient 25°C)

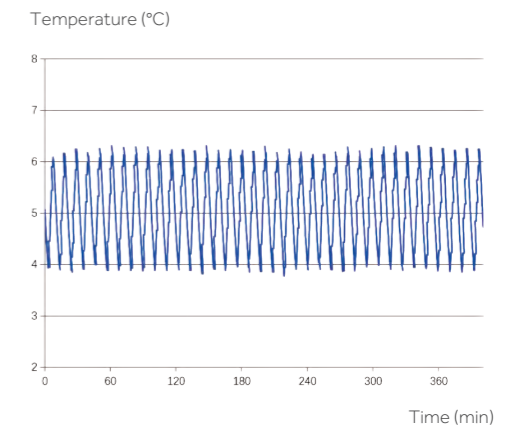

# Standard Pharmacy Refrigerator

New and improved Haier Biomedical pharmacy refrigerators now offer an improved temperature profile and more user-friendly control features.



**HYC-390**



### Technical Advantages

- Accurate temperature control maintains 2°C to 8°C throughout the unit with an adjustable increment at 0.1°C
- Improved user interface includes a data storage capacity of up to 10 years
- Oversized air-cooled condenser improves the robustness of the refrigeration system, reliability and refrigeration efficiency



### Ergonomic Design

- The temperature data of the newly improved storage management system is downloadable from the USB port
- Traceability of temperature data
- Heated double-pane glass door allows a clear view of stored products without condensation at 32°C and 85% relative humidity ambient conditions
- LED interior light saves energy and provides bright lighting of interior for easy product location and identification
- Shelves with label holders meet demands required for quick and effective product archiving and retrieving



### Safety

- Microprocessor control with digital display
- Temperature uniformity within 3°C
- Malfunction alarms include high/low temperature, door ajar, sensor error, power failure, low battery and remote alarm interface

### Temperature Curve

**HYC-390 Warm up test at 25°C ambient**

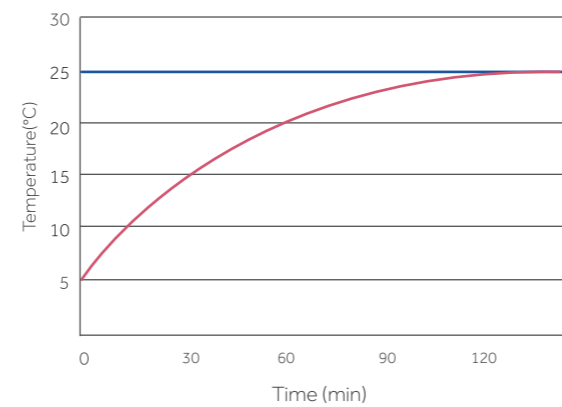

**HYC-390 Pull down test at 25°C ambient**

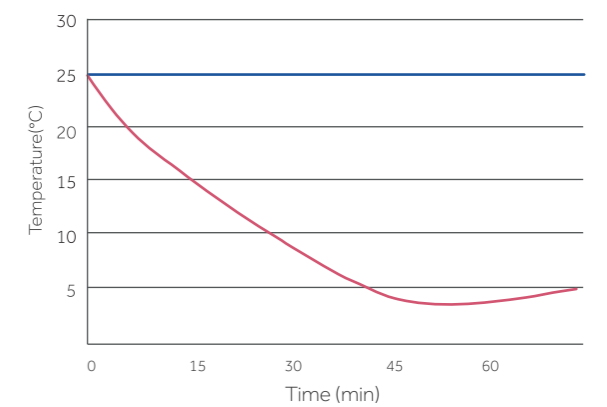

— Ambient Temperature  
— Internal Temperature

# Standard Pharmacy Refrigerator

Used for storage of biological products, vaccines, drugs, reagents, etc., the unit is widely used in pharmacies, pharmaceutical factories, hospitals, CDC, laboratories as key examples.



**HYC-410**



## Superior Performance

- Microcomputer controller, LED temperature display, accuracy 0.1°C
- Fin type evaporator and double fan system, temperature uniformity  $\pm 2^{\circ}\text{C}$
- R600a hydrocarbon refrigerant, LBA foaming agent, energy saving and environmental protection
- Optimized system and structure design, noise down to 41 dB(A)
- Panoramic glass door, LED lighting, goods are clear at a glance
- Heated door to prevent condensation
- Standard with 1 test hole, convenient for user to test interior temperature



## Safe

- Equipped with built-in lock and security latch to accommodate a padlock, ensuring safe and reliable storage
- Multiple alarms: High and low temperature, sensor error, power failure, low battery, door ajar, high ambient temperature and communication fault alarm
- Alarm mode: audible buzzer and flashing light, remote alarm. The alarm will continue for 24 hours after power failure

## Product Details

### Material:

HIPS adsorption liner, sprayed steel case

### Caster and foot:

Standard equipped with 4 universal casters and 2 adjustable feet, the refrigerator is easy to move and stabilize



**HYC-410**

### Shelves:

Standard with 6 shelves



## Product Performance

**HYC-410**  
Cooling down (ambient 32°C)

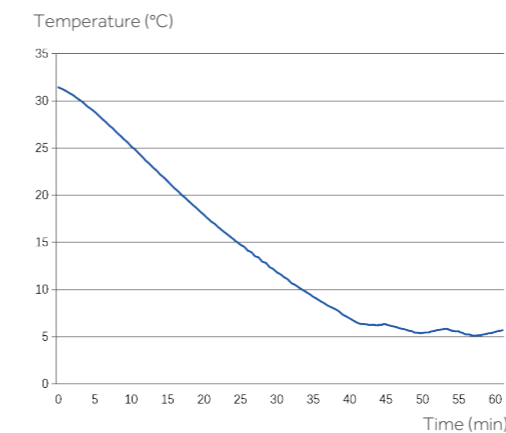

**HYC-410**  
Stability (ambient 25°C)

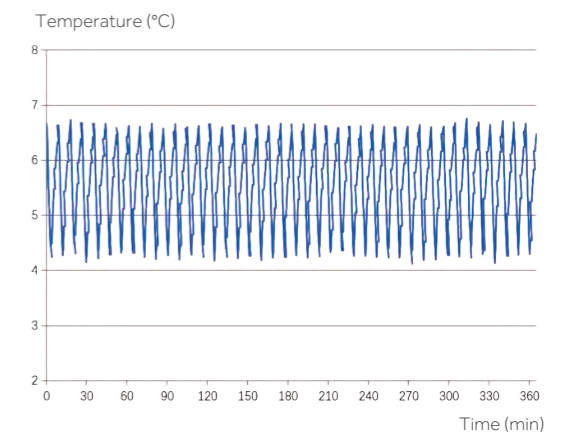

# Standard Pharmacy Refrigerator

The product is applicable to pharmacies, pharmaceutical factories, quarantine stations, health centers and hospitals, used to store biological products and those need to be stored at a temperature between 2-8°C.



220V/50HZ

115V/60HZ

**HYC-639**



### Energy saving

70mm thick foam layer, optimized refrigeration system, low power consumption, less than 6 kWh per day



### Low noise

Optimized system and structure noise reduction design



### Environmentally-friendly

Hydrocarbon refrigerant, truly completely environmental protection refrigeration system. Polyurethane insulation layer, the whole series adopts European ROHS directive materials, for environmental protection



### Multi-channel sensor, reliable and safe

Equipped with upper display sensor, lower display sensor, defrosting sensor, control sensor, ambient temperature sensor, condenser dirty sensor



### Better uniformity

Finned evaporator, double fan system. The temperature is more uniform, the characteristic point temperature uniformity is  $\pm 2^{\circ}\text{C}$

## Typical Performance Characteristics in 32°C Ambient Temp

HYC-639  
Cooling down (ambient 32°C)

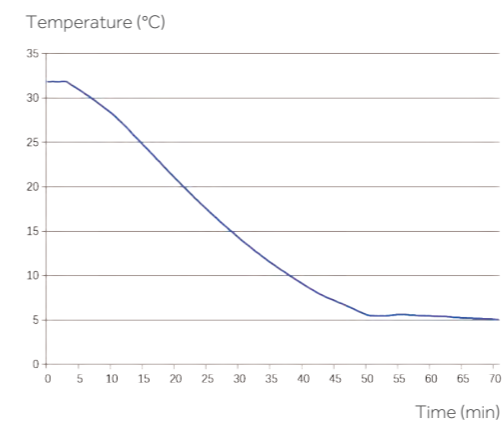

HYC-639  
Stability (ambient 25°C)

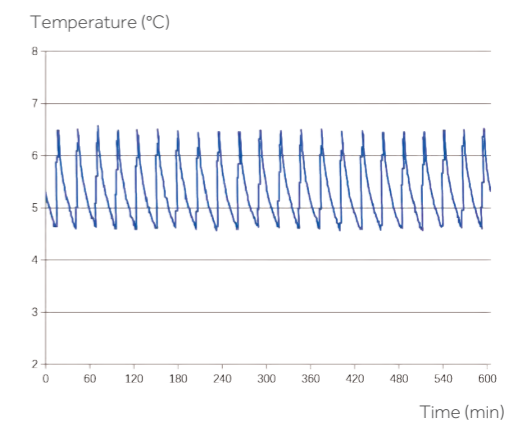

# Standard Pharmacy Refrigerator

37/38



## Microprocessor control system:

Microcomputer electronic temperature controller, LED temperature display, the display accuracy is 0.1°C

Multiple alarm functions, such as high temperature alarm, low temperature alarm, sensor error alarm, power failure alarm, low battery alarm, door ajar, condenser dirty alarm, high ambient temperature alarm as key examples.

Audio and visual alarm. The equipment can be connected to the remote alarm interface



## Insulation

70mm-thick foam insulation layer to provide better insulation



## Porthole

Standard equipped with a porthole to facilitate the user to test interior temperature



## Security lock

Equipped with safety lock, safe storage of drugs



## Temperature recorder

Standard equipped with USB port, the printer and RS485 interface are optional



## Material

The inner liner is equipped with spraying steel plate for easy cleaning



## Casters and levelling leg design

Standard equipped with 4 universal casters and 2 adjustable feet to move and stabilize the equipment



## Shelves

Standard equipped with 4 shelves

## Specifications

Model		HYC-639	HYC-639 (115V)
Technical Data	Cabinet Type	Upright, Single Door	
	Climate Class	ST	
	Cooling Type	Forced Air Cooling	
	Defrost Mode	Digital (Accuracy 0.1°C)	Auto
	Refrigerant	R600a	
	GWP (global warming potential)	20	
	Sound Level (dB(A))	43	46
Performance	Temperature Range (°C)	2-8	
	Will the fan stop automatically when opening the door	Y	
Control	Controller	Microprocessor	
	Display	LED	
Electrical Data	Power Supply (V/Hz)	220-240/50	115/60
	Electrical Current (A)	2.15	2.5
Performance Characteristics	Temperature Sensor	NTC	
	Power Consumption (kWh/24h)	5	
	Capacity (L/Cu.Ft)	639/22.6	600/21.2
Dimensions	Net/Gross Weight (approx)	(kg)	200/240
		(lbs)	551.15/639.33
	Interior Dimension (W*D*H)	(mm)	620*706*1520
		(in)	24.4*27.8*59.8
	Exterior Dimension (W*D*H)	(mm)	760*897*1993
		(in)	29.9*35.3*78.5
Packing Dimension (W*D*H)	(mm)	910*1030*2170	
	(in)	35.8*40.6*85.4	
	Container Load (20'/40'/40'H)	12/24/24	
Alarms	High/Low Temperature	Y	
	Remote Alarm	Y	
	Power Failure	Y	
	Sensor Error	Y	
	Low Battery	Y	
	Door Ajar	Y	
	Audible and Visual Alarm	Y	
Accessories	Caster	Y/4	
	Foot	Y/2	
	Porthole	Y	
	Shelves/Drawers	4/-	
	USB Interface	Y	
	Printer	Optional	
	Chart Recorder*	Optional	
Material	Exterior Material	Painted Steel	
	Interior Material	Painted Steel, Optional Stainless Steel	
	Door Thickness (mm)	30	
	Cabinet Thickness (mm)	70	
	Shelves Material	Steel Wire, Coated with Plastic	
	No. of Shelves	4	
Other	Certificate	CE, UKCA	UL, Energy Star, ANSI 456

\*The Chart recorder is equipped with 1 box of recording paper (52 sheets, one sheet per week)

# Standard Pharmacy Refrigerator

The Haier Biomedical pharmacy refrigerators are suitable for pharmacies, drug stores, pharmaceutical companies, hospitals, clinics and other pharmaceutical storage areas such as storage and logistics.



**HYC-1378**



## Durable and Reliable - Key Features

- Energy efficient hydrocarbon (HC) refrigeration system
- Permanently lubricated cooling fan for safety and longevity
- Forced-air cooling with optimized air distribution system designed to achieve maximum temperature uniformity and stability
- Optimized refrigeration system design for more effective cooling and speedy recovery
- Temperature uniformity within  $\pm 2^{\circ}\text{C}$
- Chamber temperature range  $2\text{--}8^{\circ}\text{C}$
- Microprocessor control with large digital display. Adjustable temperature with an increment of  $0.1^{\circ}\text{C}$
- Wide voltage tolerance suitable for regions with an unstable voltage supply
- Designed for ambient temperature  $10^{\circ}\text{C}\text{--}32^{\circ}\text{C}$  with humidity below 85%



## Safety

- Equipped with a complete temperature alarm system featuring audible buzzer and visible flashing light
- Capable of alerting failures due to high or low temperature, sensor error, door ajar, remote alarm, power failure and low battery



## Ergonomic Design

- Optimized space utilization design with multi-level and adjustable shelf height to accommodate the different storage requirements of varied sized pharmaceutical products.
- Safety lock to prevent unauthorized access
- Caster design and levelling feet
- Interior light

## Product Performance

**HYC-1378**  
Cooling down (ambient  $32^{\circ}\text{C}$ )

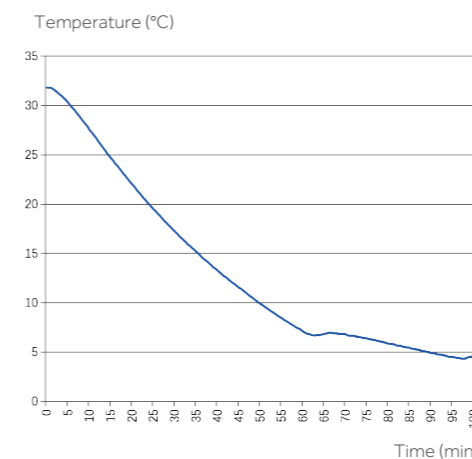

**HYC-1378**  
Stability (ambient  $25^{\circ}\text{C}$ )

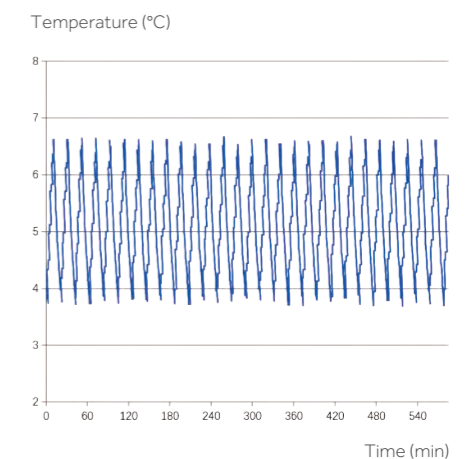

## Standard Pharmacy Refrigerator

41/42



## Specifications

Model		HYC-390F		HYC-610		HYC-290		HYC-309		HYC-390		HYC-410		
Technical Data	Cabinet Type	Upright, Single door		Upright, Single Door		Upright, Single Door		Upright, Single Door		Upright, Single Door		Upright, Single Door		
	Climate Class	N		N		ST		N		N		N		
	Cooling Type	Forced Air Cooling		Forced Air Cooling		Forced Air Cooling		Forced Air Cooling		Forced Air Cooling		Forced Air Cooling		
	Defrost Mode	Auto		Auto		Auto		Auto		Auto		Auto		
	Refrigerant	R600a		R600a		R600a		R600a		R600a		R600a		
	GWP (global warming potential)	20		20		20		20		20		20		
	Sound Level (dB(A))	43		43   45		43		41		43		41		
Performance	Temperature Range (°C)	2-8		2-8		2-8		2-8		2-8		2-8		
Control	Will the fan stop automatically when opening the door	Y		Y		Y		Y		Y		Y		
	Controller	Microprocessor		Microprocessor		Microprocessor		Microprocessor		Microprocessor		Microprocessor		
	Display	LED		LED		LED		LED		LED		LED		
Electrical Data	Power Supply (V/Hz)	220-240/50/60   115/60		220-240/50/60   115/60		220-240/50/60   115/60		220-240/50/60		220-240/50/60   115/60		220-240/50		
	Electrical Current (A)	1   1.5		3   6.2		1.8   2.2		1.9		1.8   2.4		2.0		
Performance Characteristics	Temperature Sensor	Digital Sensor		Digital Sensor		Digital Sensor		NTC		Digital Sensor		NTC		
	Power Consumption (kWh/24h)	1.5   2.5		6.6   5.5		4.4   5.1		4.5		43		5.5		
Dimensions	Capacity (L/Cu.Ft)	390/13.8		610/21.6		290/10.2		309/10.9		390/13.8		410/14.5		
	Net/Gross Weight (approx)	(kg)	106/129		204/227		105/127		77/87		116/139		116/139	
		(lbs)	233.8/284.5		449.7/500.4		231.6/280.1		170/192		255.8/306.6		255.7/306.4	
	Interior Dimension (W*D*H)	(mm)	530*555*1380		680*640*1400		530*555*1080		525*500*1290		530*555*1380		530*590*1380	
		(in)	20.9*21.9*54.3		26.8*25.2*55.1		20.9*21.9*42.5		20.7*19.7*50.8		20.9*21.9*54.3		20.9*22.8*54.3	
	Exterior Dimension (W*D*H)	(mm)	665*710*1965		780*840*1945		665*710*1665		600*630*1840		665*710*1965		665*710*1965	
		(in)	26.2*28.0*77.4		30.7*33.1*76.6		26.2*28.0*65.6		23.6*24.8*72.4		26.2*28.0*77.4		26.2*28.0*77.4	
	Packing Dimension (W*D*H)	(mm)	710*810*2130		885*965*2110		700*810*1810		680*690*1940		710*810*2130		710*810*2130	
(in)		27.6*31.9*83.9		34.8*38.0*83.1		27.6*31.9*71.3		26.8*27.1*74.4		27.6*31.9*83.9		27.6*31.9*83.9		
Container Load (20'/40'/40'H)		22/44/44		12/26/26		22/44/44		24/51/51		22/44/44		22/44/44		
Alarms	High/Low Temperature	Y		Y		Y		Y		Y		Y		
	Remote Alarm	Y		Y		Y		Y		Y		Y		
	Power Failure	Y		Y		Y		Y		Y		Y		
	Sensor Error	Y		Y		Y		Y		Y		Y		
	Low Battery	Y		Y		Y		Y		Y		Y		
	Door Ajar	Y		Y		Y		Y		Y		Y		
	Audible and Visual Alarm	Y		Y		Y		Y		Y		Y		
Accessories	Caster	Y		Y		Y		Y		Y		4		
	Foot	Y		Y		Y		Y		Y		2		
	Porthole	Y		Y		Y		Y		Y		Y		
	Shelves/Drawers	7/-		6/-		5/-		5/-		7/-		6/-		
	USB Interface	Optional   Y		Optional		Optional   Y		Optional		Optional   Y		Optional		
	Printer	Optional		/		Optional		Optional		Optional		Optional		
Material	Exterior Material	Painted Steel		Painted Steel		Painted Steel		Painted Steel		Painted Steel		Painted Steel		
	Interior Material	Polystyrene		Stainless Steel		Polystyrene		Polystyrene		Polystyrene		Polystyrene		
	Door Thickness (mm)	40		40		40		40		40		45		
	Cabinet Thickness (mm)	40		50		40		38		40		40		
	Shelves Material	Steel Wire, Coated with Plastic		Steel Wire, Coated with Plastic		Steel Wire, Coated with Plastic		Steel Wire, Coated with Plastic		Steel Wire, Coated with Plastic		Steel Wire, Coated with Plastic		
	No. of Shelves	7		6		5		5		7		6		
Other	Certificate	CE   UL		CE   UL		CE   UL		CE, UKCA		CE   UL		CE, ENERGY STAR		

## Standard Pharmacy Refrigerator



## Specifications

Model		HYC-940		HYC-940F		HYC-1378		
Technical Data	Cabinet Type	Upright, Double Glass Door		Upright, Double Solid Door		Upright, Double Door		
	Climate Class	N		N		N		
	Cooling Type	Forced Air Cooling		Forced Air Cooling		Forced Air Cooling		
	Defrost Mode	Auto		Auto		Auto		
	Refrigerant	R290		R290		R290		
	GWP (global warming potential)	3		3		3		
	Sound Level (dB(A))	43	45	43	43	45		
Performance	Temperature Range (°C)	2-8		2-8		2-8		
Control	Will the fan stop automatically when opening the door	Y		Y		Y		
	Controller	Microprocessor		Microprocessor		Microprocessor		
	Display	LED		LED		LED		
Electrical Data	Power Supply (V/Hz)	220-240/50/60	115/60	220-240/50/60	220-240/50/60	115/60		
	Electrical Current (A)	3.5	7.5	2.7	3	7.35		
Performance Characteristics	Temperature Sensor	NTC		NTC		NCT		
	Power Consumption (kWh/24h)	11		11		11	12.47	
Dimensions	Capacity (L/Cu.Ft)	890/31.4		890/31.4		1378/48.7		
	Net/Gross Weight (approx)	(kg)	227/279		207/259		310/360	
		(lbs)	500.4/615.1		456.4/571.1		683.4/793.7	
	Interior Dimension (W*D*H)	(mm)	1030*590*1425		1030*590*1425		1320*700*1500	
		(in)	40.6*23.2*56.1		40.6*23.2*56.1		52.0*27.6*59.1	
	Exterior Dimension (W*D*H)	(mm)	1130*755*1980		1130*755*1980		1440*950*1980	
		(in)	44.5*29.7*78.0		44.5*29.7*78.0		56.7*37.4*78.0	
	Packing Dimension (W*D*H)	(mm)	1250*850*2170		1250*850*2170		1620*1040*2140	
		(in)	49.2*33.5*85.4		49.2*33.5*85.4		63.8*41.0*84.3	
		Container Load (20'/40'/40'H)	10/22/22		10/22/22		6/14/14	
Alarms	High/Low Temperature	Y		Y		Y		
	Remote Alarm	Y		Y		Y		
	Power Failure	Y		Y		Y		
	Sensor Error	Y		Y		Y		
	Low Battery	Y		Y		Y		
	Door Ajar	Y		Y		Y		
	Audible and Visual Alarm	Y		Y		Y		
Accessories	Caster	Y		Y		Y		
	Foot	Y		Y		Y		
	Porthole	Y		Y		Y		
	Shelves/Drawers	12/-		12/-		12/-		
	USB Interface	Optional		Optional		Y		
	Printer	Optional		Optional		Optional		
	Chart Recorder	N/A		N/A		Optional		
Material	Exterior Material	Painted Steel		Painted Steel		Painted Steel		
	Interior Material	Painted Steel		Painted Steel		Painted Steel		
Other	Certificate	CE	UL	CE	CE	UL		

# Under-Counter Pharmacy Refrigerator

45/46

## Easy to Install, Ergonomic and Reliable

Haier Biomedical are pioneers in under-counter pharmacy refrigerator design and manufacturing, offering ultra-low noise system, safety lock, complete alarm system for sample safety and protection.



HYC-118

HYC-118A



### Reliability and Key Features

- Energy efficient hydrocarbon (HC) refrigeration system
- Permanently lubricated cooling fan for safety and longevity
- Forced-air cooling with optimized air distribution system designed to achieve maximum temperature uniformity and stability
- Optimized refrigeration system design for more effective cooling and speedy recovery
- Temperature uniformity within  $\pm 3^{\circ}\text{C}$
- Chamber temperature range  $2\text{-}8^{\circ}\text{C}$
- Microprocessor control, digital display and temperature adjustment with an increment of  $0.1^{\circ}\text{C}$
- Designed for ambient temperature  $10\text{-}32^{\circ}\text{C}$  with humidity below 70%



### Safety

- Equipped with a complete temperature alarm system featuring audible buzzer and visual flashing light
- Capable of alerting failures due to high and low temperature, sensor error, door ajar, power failure, and remote alarm interface



### Ergonomic Design

- Interior LED light
- Safety lock to prevent unauthorized access

## Product Performance

HYC-118A  
Cooling down (ambient  $32^{\circ}\text{C}$ )

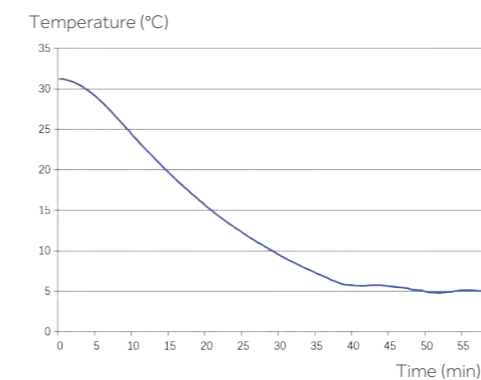

HYC-118A  
Stability (ambient  $25^{\circ}\text{C}$ )

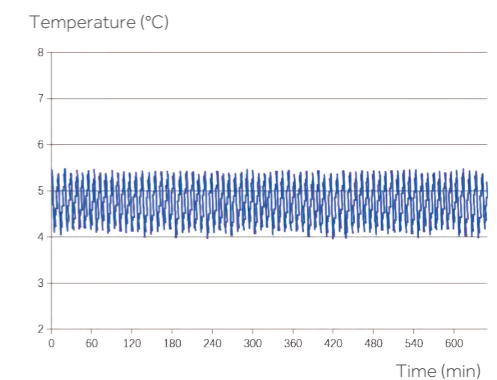

## Under-Counter Pharmacy Refrigerator



## Specifications

Model		HYC-68		HYC-68A		HYC-118		HYC-118A		
Technical Data	Cabinet Type	Upright, Solid Door		Upright, Glass Door		Upright, Solid Door		Upright, Glass Door		
	Climate Class	N		N		N		N		
	Cooling Type	Forced Air Cooling		Forced Air Cooling		Forced Air Cooling		Forced Air Cooling		
	Defrost Mode	Auto		Auto		Auto		Auto		
	Refrigerant	R600a		R600a		R600a		R600a		
	GWP (global warming potential)	20		20		20		20		
	Sound Level (dB(A))	41		41		41		41		
Performance	Temperature Range (°C)	2-8		2-8		2-8		2-8		
Control	Will the fan stop automatically when opening the door	Y		Y		Y		Y		
	Controller	Microprocessor		Microprocessor		Microprocessor		Microprocessor		
	Display	LED		LED		LED		LED		
Electrical Data	Power Supply (V/Hz)	220-240/50	115/60	220-240/50	115/60	220-240/50/60	115/60	220-240/50/60	115/60	
	Electrical Current (A)	0.85	2.5	0.85	1.7	1.4	1.5	1.4	1.5	
Performance Characteristics	Temperature Sensor	NTC		NTC		NTC		NTC		
	Power Consumption (kWh/24h)	0.6		0.9		0.42		1.7		
	Temperature Sensor or Not	Y		Y		Y		Y		
Dimensions	Capacity (L/Cu.Ft)	68/2.4		68/2.4		118/4.2		118/4.2		
	Net/Gross Weight (approx)	(kg)	38/40		38/40		41/46		46/51	
		(lbs)	83.8/88.2		83.8/88.2		90.5/101.5		101.5/112.5	
	Interior Dimension (W*D*H)	(mm)	415*385*505		415*385*505		515*415*630		515*415*630	
		(in)	16.3*15.2*19.9		16.3*15.2*19.9		20.3*16.3*24.8		20.3*16.3*24.8	
	Exterior Dimension (W*D*H)	(mm)	495*580*660		495*580*660		597*635*810		597*635*810	
		(in)	19.5*22.8*26.0		19.5*22.8*26.0		23.5*25.0*31.9		23.5*25.0*31.9	
	Packing Dimension (W*D*H)	(mm)	570*670*750		570*670*750		700*710*930		700*710*930	
(in)		22.5*26.4*29.5		22.5*26.4*29.5		27.6*28.0*36.6		27.6*28.0*36.6		
Container Load (20'/40'/40'H)	102/207/207		102/207/207		48/96/96		48/96/96			
Alarms	High/Low Temperature	Y		Y		Y		Y		
	Remote Alarm	Y		Y		Y		Y		
	Power Failure	Y		Y		Y		Y		
	Sensor Error	Y		Y		Y		Y		
	Low Battery	Y		Y		Y		Y		
	Audible and Visual Alarm	Y		Y		Y		Y		
	Door Ajar	Y		Y		Y		Y		
Accessories	Foot	Y/2		Y/2		Y/2		Y/2		
	Porthole	Y; 1 Right Side Wall		Y; 1 Right Side Wall		Y; 1 Left Side Wall		Y; Left Side Wall		
	Shelves/Drawers	2/1		2/1		3/1		3/1		
	USB Interface	Optional		Optional		/		/		
	Exterior Material	Painted Steel		Painted Steel		Painted Steel		Painted Steel		
Material	Interior Material	Polystyrene		Polystyrene		Polystyrene		Polystyrene		
	Drawers Material	Steel Wire Dipping Plastic		Steel Wire Dipping Plastic		Steel Wire Dipping Plastic		Steel Wire Dipping Plastic		
	Door Thickness (mm)	30		30		40		40		
	Cabinet Thickness (mm)	30		30		40		40		
	Shelves Material	Steel Wire, Coated with Plastic		Steel Wire, Coated with Plastic		Steel Wire, Coated with Plastic		Steel Wire, Coated with Plastic		
	No. of Shelves	2		2		3		3		
	Other	Certificate	CE, UKCA	UL	CE, UKCA	UL	CE, UKCA	UL	CE, UKCA	UL

# Combined Refrigerator and Freezer

This product is designed to store biomaterials, vaccines, electronic devices and low temperature tests of special materials, in hospitals, epidemic prevention stations, universities, scientific research institutes, electronic chemical industry and other enterprise laboratories.



HYCD-282

HYCD-282A



### Multipurpose and Space Efficient

- One cabinet with two independent chambers, both are self-contained and independently controlled with individual doors
- Refrigerator chamber is equipped with a double-paned glass viewing window and LED interior lighting



### Environment Friendly

Hydrocarbon refrigerant (R600a for refrigerator/ R290 for freezer) and CFC-free polyurethane insulation for reduced global warming



### Stainless Steel Interior

The interior of refrigerator and freezer are both made of stainless steel, which is easy to clean and corrosion-proof



### Microprocessor Controller with Digital Display

- Refrigerator temperature 2~8°C with resolution of 0.1°C
- Freezer temperature -40~-10 ° C with resolution of 1°C
- Multiple alarm functions with remote alarm contact to ensure safe monitoring



### High Performance

- Refrigerator: Forced-air cooling system with cycle defrost, temperature uniformity±3°C
- Freezer: Cold wall cooling system, manual defrost, temperature uniformity±5°C
- Standard USB port & optional printer, easy to get temperature record

## Product Performance

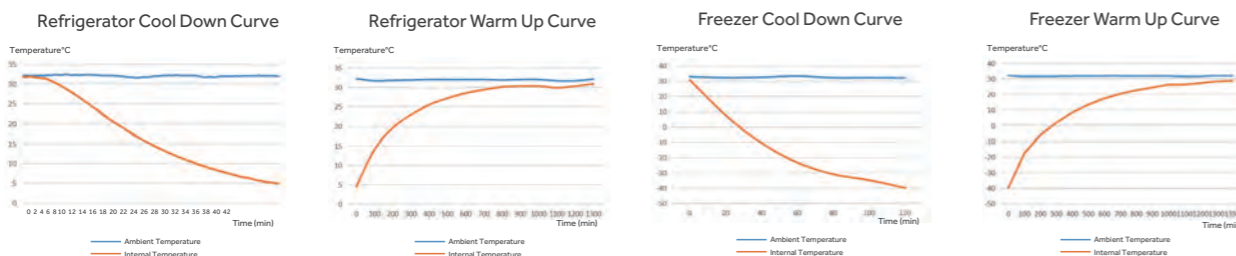

## Specifications

	Model		HYCD-282		HYCD-282A	
	Refrigerator	Freezer	Refrigerator	Freezer	Refrigerator	Freezer
Technical Data	Cabinet Type		Upright		Upright	
	Climate Class		N		N	
	Cooling Type		Forced air cooling	Direct cooling	Forced air cooling	Direct cooling
	Defrost Mode		Auto	Manual	Auto	Manual
	Refrigerant		HC	HC	HC	HC
	GWP (global warming potential)		R600a:20	R290:3	R600a:20	R290:3
Performance	Sound Level (dB(A))		43		43	
	Temperature Range (°C)		2-8	-10~-40	2-8	-10~-40
Control	Controller		Microprocessor		Microprocessor	
	Display		LED		LED	
Electrical Data	Power Supply (V/Hz)		220-240/50/60		220-240/50/60	
	Power (W)		410		410	
	Electrical Current (A)		2.5		2.5	
Dimensions	Capacity (L/Cu.Ft)		185/6.5	97/3.4	185/6.5	97/3.4
	Net/Gross Weight (approx)	kg	145/160		145/160	
		lbs	319.7/352.7		319.7/352.7	
	Interior Dimensions (W*D*H)	mm	605*510*720	515*465*440	605*510*720	515*465*440
		in	23.8*20*28.3	20.2*18.3*17.3	23.8*20*28.3	20.2*18.3*17.3
	Exterior Dimensions (W*D*H)	mm	735*660*1810		735*660*1810	
		in	28.9*26.0*71.3		28.9*26.0*71.3	
	Packing Dimensions (W*D*H)	mm	795*740*2010		795*740*2010	
		in	31.3*29.1*79.1		31.3*29.1*79.1	
	Container Load (20'/40'/40'H)		21/43/43		21/43/43	
Alarms	High/Low Temperature		Y		Y	
	Door Ajar		Y		Y	
	Remote Alarm		Y		Y	
	Power Failure		Y		Y	
	Sensor Error		Y		Y	
	Low Battery		Y		Y	
	High Ambient Temp		Y		Y	
Accessories	Caster		Y/4		Y/4	
	Foot		Y/2		Y/2	
	Porthole		Y/2		Y/2	
	Shelves/Drawers		3/1	1/2	3/1	1/2
	Stylus Printer		Optional		Optional	
	USB Interface		Y		Y	
Others	Certification		CE		CE	
Compressor Type		Frequency Conversion Compressor		Frequency Conversion Compressor		
Compressor Quantity		2		2		

# Combined Refrigerator and Freezer

This product is designed to store biomaterials, vaccines, electronic devices and low temperature tests of special materials.



HYCD-469



Temperature Control

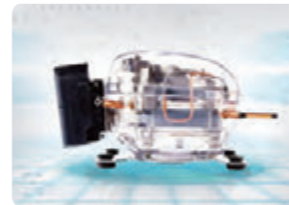

Security Guaranteed



Variable Frequency Hydrocarbon Refrigeration System



Data Storage

## Key Features



### Temperature Control

- Refrigerator temperature ranges from 2°C to 8°C
- Freezer temperature ranges adjustable from -10°C to -40 °C
- Microprocessor temperature control accuracy 0.1°C (refrigerator) and 1°C (freezer)



### Safety

- Separate doors for refrigerator and freezer with independent lock catches, dual padlocks available to ensure product safety
- Multiple alarm functions including high or low temperature, sensor error, high ambient temp, power failure and remote alarm
- Two types of alarm indicators: audible buzzer and visible flashing light



### Refrigerator System

- Refrigerator and freezer have independently controlled variable frequency refrigeration systems, standalone displays as well as separate on and off controls
- Robust compressor system operating with environmentally friendly hydrocarbon refrigerant
- Refrigerator with high quality and high efficiency cooling fan provides better temperature uniformity and stability

## Specifications

	Model	HYCD-319A(115V)		HYCD-469		HYCD-469A		HYCD-469A(115V)		
		Refrigerator	Freezer	Refrigerator	Freezer	Refrigerator	Freezer	Refrigerator	Freezer	
Technical Data	Cabinet Type	Upright		Upright		Upright		Upright		
	Climate Class	N		N (16-32°C)		N (16-32°C)		N (16-32°C)		
	Cooling Type	Forced Air Cooling	Direct Cooling	Forced Air Cooling	Direct Cooling	Forced Air Cooling	Direct Cooling	Forced Air Cooling	Direct Cooling	
	Defrost Mode	Auto	Manual	Auto	Manual	Auto	Manual	Auto	Manual	
	Refrigerant	R600a	R290	R600a	R290	R600a	R290	R600a	R290	
	GWP (global warming potential)	R600a:20	R290:3	R600a:20	R290:3	R600a:20	R290:3	R600a:20	R290:3	
	Sound Level (dB(A))	50		45		45		52		
	Performance	Temperature Range (°C)	2-8	-15~-40	2-8	-10~-40	2-8	-10~-40	2-8	-15~-40
Control	Controller	Microprocessor		Microprocessor		Microprocessor		Microprocessor		
	Display	LED		LED		LED		LED		
Electrical Data	Power Supply (V/Hz)	115/60		220-240/50/60		220-240/50/60		115/60		
	Power (W)	450		640		640		640		
	Electrical Current (A)	6		3		3		7		
Dimensions	Capacity (L/Cu.Ft)	200/7.06	100/3.53	269/9.5	200/7.1	269/9.5	200/7.1	245/8.65	200/7.1	
	Net/Gross Weight (approx)	kg	145/160		176/207		176/207		176/207	
		lbs	319.7/352.7		388.0/456.4		388.0/456.4		388.0/456.4	
	Interior Dimensions (W*D*H)	mm	605*510*720	515*465*440	593*585*800	553*545*660	593*585*800	553*545*660	593*585*800	553*545*660
		in	23.8*20*28.3	20.2*18.3*17.3	23.3*23.0*31.5	21.8*21.5*26.0	23.3*23.0*31.5	21.8*21.5*26.0	23.3*23.0*31.5	21.8*21.5*26.0
	Exterior Dimensions (W*D*H)	mm	735*660*1810		738*834*1975		738*834*1975		738*834*1975	
		in	28.9*26.0*71.3		29.1*32.8*77.8		29.1*32.8*77.8		29.1*32.8*77.8	
	Packing Dimensions (W*D*H)	mm	795*740*2010		840*910*2170		840*910*2170		840*910*2170	
		in	31.3*29.1*79.1		33.1*35.8*85.4		33.1*35.8*85.4		33.1*35.8*85.4	
	Container Load (20'/40'/40'H)		21/43/43		12/28/28		12/28/28		12/28/28	
Alarms	High/Low Temperature	Y		Y		Y		Y		
	Sensor Error	Y		Y		Y		Y		
	Power Failure	Y		Y		Y		Y		
	Door Ajar	Y		Y		Y		Y		
	Remote Alarm	Y		Y		Y		Y		
	High Ambient Temperature	Y		Y		Y		Y		
	Low Battery	Y		Y		Y		Y		
	Caster	Y/4		Y		Y		Y		
Accessories	Foot	Y/2		Y		Y		Y		
	Porthole	Y/2		Y		Y		Y		
	Shelves/Drawers	3/1	1/2 (Without Sliding Rack)	3/0	3/0 (Max 3 Drawers optional, without sliding rack)	3/0	3/0 (Max 3 Drawers optional, without sliding rack)	3/0	3/0 (Max 3 Drawers optional, without sliding rack)	
Others	USB Interface	Y		Y		Y		Y		
Certification	UL		CE		CE		UL			

# Laboratory Refrigerator

53/54



## Typical Installation

Used to store chemicals, reagents and consumables within laboratories and research facilities.

## Product advantages

### Precise Control of Temperature

Adjustable set temperature range is 3°C to 16°C. A smart temperature control system keeps the internal temperature variation within ±3°C inside the chamber.

### High Efficiency HC Cooling Technology

The hydrocarbon refrigeration system operates at a much higher efficiency and reduces the energy consumption by about 50 percent.



## Ergonomic Design

### One-touch Search for Historic Data

The highest and lowest historic temperature data is saved and can be checked with one key stroke.

### Precise Control of Temperature

Adjustable set temperature range is 3°C to 16°C. A smart temperature control system keeps the internal temperature variation within ±3°C inside the chamber.

### High Strength Glass Shelves

Tempered glass shelves hold 24kg of products per shelf.

### Automatic Door Closing Function

### Low Noise

Noise cancelling technology reduces the sound level to less than 40 dB(A) for an improved working environment.

### HC High Efficiency HC Cooling Technology

The hydrocarbon refrigeration system operates at a much higher efficiency and reduces the energy consumption by about 50 percent.

### Dual Lock Design with Multiple Alarm Systems

A mortise lock is standard on the door with option to add a padlock for additional security. Standard alarms include high and low temperature, door opening, and sensor errors.



Cabinet Structure



Glass Shelf



Fan/Interior Light



Display Board

## Specifications

	Model	HLR-310F	
Technical Data	Type	Upright	
	Climate Class	N	
	Cooling Type	Forced Air Cooling	
	Defrost Mode	Auto	
	Refrigerant	R600a	
	GWP (global warming potential)	20	
	Sound Level (dB(A))	40	
Performance	Temperature Range (°C)	3-16 Adjustable	
	Ambient Temperature (°C)	16-32	
Control	Controller	Microprocessor	
	Display	LED	
Electrical Data	Power Supply (V/Hz)	220-240/50	
	Power (W)	225	
	Electrical Current (A)	1.6	
Performance Characteristics	Temperature Sensor	NTC	
	Power Consumption (kWh/24h)	1.05	
Dimensions	Capacity (L/Cu.Ft)	310/10.9	
	Net/Gross Weight	kg	72/83
		lbs	158.7/183
	Interior Dimensions (W*D*H)	mm	560*500*1290
		in	22.0*19.7*50.8
	Exterior Dimensions (W*D*H)	mm	605*598*1840
		in	23.8*23.6*73.6
	Packing Dimensions (W*D*H)	mm	680*690*1940
		in	26.8*27.1*74.4
	Container Load (20'/40'/40'H)		24/51/51
Alarms	High/Low Temperature	Y	
	Sensor Error	Y	
	Door Ajar	Y	
	Audible and Visual Alarm	Y	
Accessories	Caster	4	
	Foot	2	
	Porthole	Y	
	Shelves	4	
Material	Temperature Setting Mode	Password Protection	
	Exterior Material	Painted Steel	
	Interior Material	Polystyrene	
	Door Thickness (mm)	45	
	Cabinet Thickness (mm)	35	
	No. of Shelves	4	
Others	Certification	CE	

# Spark Free Refrigerator

## Typical Installation

Spark free refrigerators are installed typically in many different laboratories and research facilities to store chemical or experimental reagents that are flammable, explosive, evaporative or corrosive.



HLR-310SF/FL

## Product Advantages

### ATEX II C-T6 E.U. Explosion Proof Certification

Explosion proof features include antistatic liner, gasket, explosion proof fan motor, over current and voltage protection. ATEX II C-T6 explosion proof certification for Haier's laboratory refrigerator ensures safety in your work place.

### 3~16°C Setting Temperature Range

Smart temperature control system limits the temperature variance within  $\pm 3^{\circ}\text{C}$ . Adjustable set point for the range of  $3^{\circ}\text{C} \sim 16^{\circ}\text{C}$ , factory default set temperature is  $5^{\circ}\text{C}$ , controlling the temperature inside the chamber is  $2 \sim 8^{\circ}\text{C}$ .

### One-touch Search for Historic Data

The highest and lowest historic temperature data is saved and can be checked with one keystroke.

### High Efficiency HC Cooling Technology

The hydrocarbon refrigeration system operates at a much higher efficiency and reduces the energy consumption by about 50 percent.

## Ergonomic Design

### High Strength Glass Shelves

Tempered glass shelves hold 40 kg of products per shelf.

### Low Noise

Noise cancelling technology reduces the sound level to less than 40 dB(A) for a much-improved environment.



### Dual Lock Design with Multiple Alarm Systems

A mortise lock is standard on the door. Standard alarms include high and low temperature, door ajar, and sensor errors.



Cabinet Structure



Glass Shelf

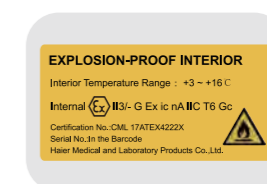

ATEX Certification Label



Explosion Proof Cabinet/Fan

# Spark Free Refrigerator

## Application Range

Haier spark free refrigerators are ATEX certified in the application range II 3G Ex ic nA II T6, which means the appliances can be found in the whole II zone environment (including II A and II B, II C), a typical environment within many biochemistry laboratories.

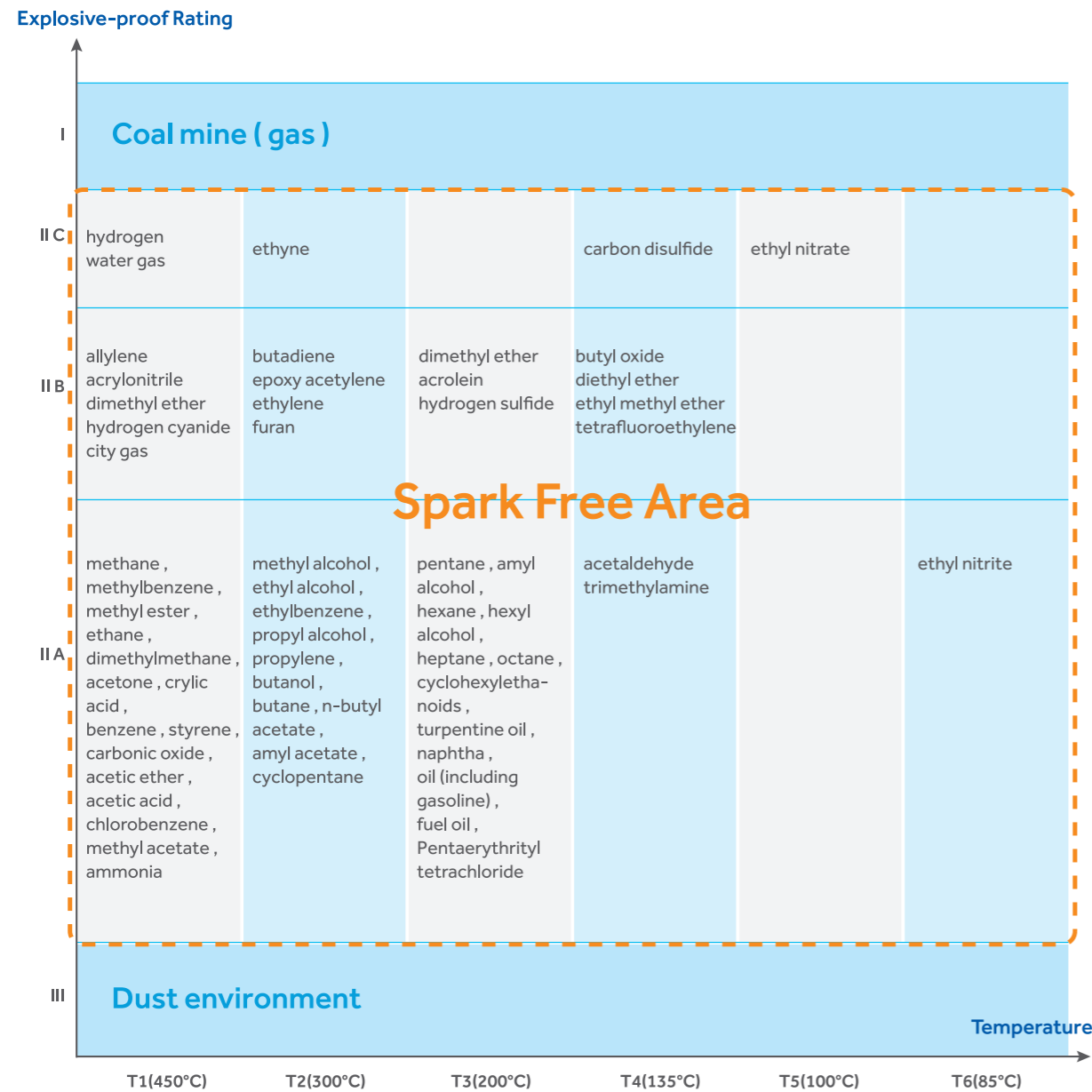

**Warning: Do not store open containers of volatile substances in this refrigerator.**

## Specifications



Model	HLR-118SF	HLR-310SF	HLR-310FL(115V)	HLR-310FL(220V)
Type	Under-Counter	Upright	Upright	Upright
Climate Class	N	N	N	N
Cooling Type	Forced Air Cooling	Forced Air Cooling	Forced Air Cooling	Forced Air Cooling
Defrost Mode	Auto	Auto	Auto	Auto
Refrigerant	R600a	R600a	R600a	R600a
GWP (global warming potential)	20	20	20	20
Sound Level (dB(A))	40	40	43	40
Temperature Range (°C)	3-16 Adjustable	3-16 Adjustable	3-16 Adjustable	3-16 Adjustable
Ambient Temperature (°C)	16-32	16-32	16-32	16-32
Controller	Microprocessor	Microprocessor	Microprocessor	Microprocessor
Display	LED	LED	LED	LED
Power Supply (V/Hz)	220-240/50	220-240/50	115/60	220-240/50
Power (W)	55	210	210	210
Electrical Current (A)	1.2	1.26	2.5	1.26
Power Consumption (kWh/24h)	0.56	1.05	1.05	1.05
Capacity (L/Cu.Ft)	118/4.2	310/10.9	310/10.9	310/10.9
Net/Gross Weight (approx)	kg	44/49	72/83	72/83
	lbs	97/108	158.7/183	158.7/183
Interior Dimensions (W*D*H)	mm	515*415*630	560*500*1290	560*500*1290
	in	20.3*16.3*24.8	22.0*19.7*50.8	22.0*19.7*50.8
Exterior Dimensions (W*D*H)	mm	597*635*810	605*598*1840	605*598*1840
	in	23.5*25*31.9	23.8*23.6*73.6	23.8*23.6*73.6
Packing Dimensions (W*D*H)	mm	700*710*930	680*690*1940	680*690*1940
	in	27.6*28.0*36.6	26.8*27.1*74.4	26.8*27.1*74.4
Container Load (20'/40'/40'H)	48/96/96	24/51/51	24/51/51	24/51/51
High/Low Temperature	Y	Y	Y	Y
Sensor Error	Y	Y	Y	Y
Door Ajar	Y	Y	Y	Y
Caster	2	4	4	4
Foot	2	2	2	2
Shelves/Baskets	2/1	4/0	4/0	4/0
Water Tray	1	1	1	1
Padlock Adapter Kit/Quantity	/	1	1	1
Built-in Key Door Lock/Quantity	1	1	1	1
CE	Y	Y	Y	Y
ATEX	Y	Y	Y	Y

## Combined Refrigerator and Freezer with Spark-free Interior

This application is suitable for storing highly inflammable products such as research samples, reagents, and other laboratory inventories within specific temperature ranges. The refrigerator chamber maintains temperatures between 3-16°C, while the freezer chamber can reach temperatures of -10--30°C. This setup provides a controlled environment for storing sensitive materials safely.

### Product Advantages

-  USB module, printer and RS485 are all available for easy data acquisition and external connection
-  Multiple alarm functions for safer monitoring, audible/visual alert with mute function; remote alarm contact is equipped as standard
-  Eco-friendly hydrocarbon refrigerant and CFC-free polyurethane insulation for reduced GWP (global warming potential)
-  Stainless steel Interior and stainless shelves (adjustable for refrigerator chamber and removable for freezer chamber)
-  Both refrigerator chamber and freezer chamber have an independent cooling circuit
-  Hermetically sealed compressor, optimized cooling system to ensure high performance and energy saving
-  Effortless Mobility and Stability with 4 Swivel Casters and 2 Levelling Feet
-  Heavy duty dandles with unique-key lock and hasp for padlock
-  ATEX Certified with spark-free interior
-  Microprocessor controller with digital display



**HLRF-319SF**

### Cabinet Temperature

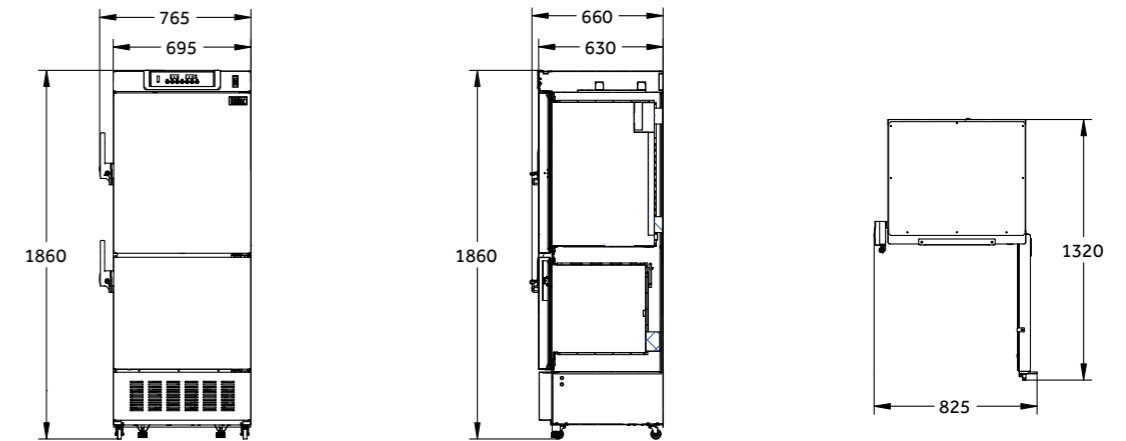

### Specifications

Model		HLRF-319SF	
		Refrigerator	Freezer
Technical Data	Cabinet Type	Upright	
	Climate Class	N, 16-32°C	
	Cooling Type	Forced Air Cooling	Direct Cooling
	Defrost Mode	Auto	Manual
	Refrigerant	R600a	R290
	GWP (global warming potential)	R600a:20	R290:3
	Sound Level (dB(A))	43	
Performance	Temperature Range (°C)	2-8	-10--40
Control	Controller	Microprocessor	
	Display	LED	
Electrical Data	Power Supply (V/Hz)	220-240/50	
	Power (W)	230	
	Electrical Current (A)	1.5	
	Power Consumption (kWh/day)	1.5	
Dimensions	Capacity (L/Cu.Ft)	219/7.7	100/3.5
	Net/Gross Weight (approx)	kg	130/140
		lbs	320/353
	Interior Dimensions (W*D*H)	mm	605*510*720
		in	23.8*20*28.3
	Exterior Dimensions (W*D*H)	mm	735*660*1810
		in	28.9*26.0*71.3
Packing Dimensions (W*D*H)	mm	795*740*2010	
	in	31.3*29.1*79.1	
Alarms	Container load (20'/40'/40'H)	21/43/43	
	High/Low Temperature	Y	
	Sensor Error	Y	
	Power Failure	Y	
	Door Ajar	Y	
	Low Battery	Y	
	Remote Alarm	Y	
Accessories	Caster	Y/4	
	Foot	Y/2	
	Porthole	N/A	
	Shelves	3 Adjustable	2 Removeable
Others	Stylus Printer	Optional (Printer or RS485, Either-or)	
	RS485	Optional (Printer or RS485, Either-or)	
	USB Interface	Optional	
	Certification	CE, ATEX	

# Fluid Warming Cabinet

61/62

## Application

Heating applications include warming of liquid medicine, nutrient solution, rinsing liquid and physiological saline. Installations can be found in operating rooms, ICU, emergency rooms, wards and other related areas.



## Product Features

- Fast heating speed: variable power PTC heating module with fast heating speed and energy saving.
- UV sterilization: UV light sterilization in the cabinet with a variety of optional sterilization methods for effective prevention of possible contamination.
- Multiple overheat protections: electronic control + mechanical temperature control + overheat protection, multiple temperature control to ensure heating safety.
- Environmentally friendly: no compressor or external fan, extremely quiet with no disturbance to the airflow in the operating room and no effect on temperature, reduces risks of cross-contamination.



UV Sterilization Lamp

## Product Advantages

- Fast and efficient heating.
- Standard UV sterilization for effective sterilization and other sterilization options available.
- Multiple over heating protections to ensure product viability.
- Two-sensor.



7 Inch LCD Screen

## Ergonomic Design

- Large and clear 7-inch LCD touch screen.
- Easy to clean stainless steel interior and flat external surfaces.
- Multiple alarms for over-heating protection.

## Specifications



Model		HYR-111	
Technical Data	Cabinet Type	Upright, One Glass Door	
	Climate Class	SN	
	Warming Type	Forced Air Warming	
	Sound Level (dB(A))	42	
Performance	Temperature Range (°C)	26°C-50°C, Above Ambient Temperature	
Control	Controller	Microprocessor	
	Display	LCD Touch Screen	
Electrical Data	Power Supply (V/Hz)	220-240/50/60	
	Power(W)	130	
	Power Consumption (kWh/24h)	0.59	
Dimensions	Capacity (L/Cu.Ft)	111/3.9	
	Net/Gross Weight (approx)	kg	58/68
		lbs	127.6/149.6
	Interior Dimensions (W*D*H)	mm	477*528*462
		in	18.67*20.67*18.1
	Exterior Dimensions (W*D*H)	mm	597*682*833
		in	23.37*26.7*32.61
	Packing Dimensions (W*D*H)	mm	700*775*960
in		27.6*30.5*37.8	
	Container load (20'/40'/40'H)	46/94/94	
Alarms	High/Low Temperature	Y	
	Sensor Error	Y	
	Door Ajar	Y	
Accessories	Caster	Y	
	Foot	Y	
	Porthole	Y	
	Shelves	Y	